

88 5180 307 Arts & Crafts Dining Hutch (Cottage Oak)

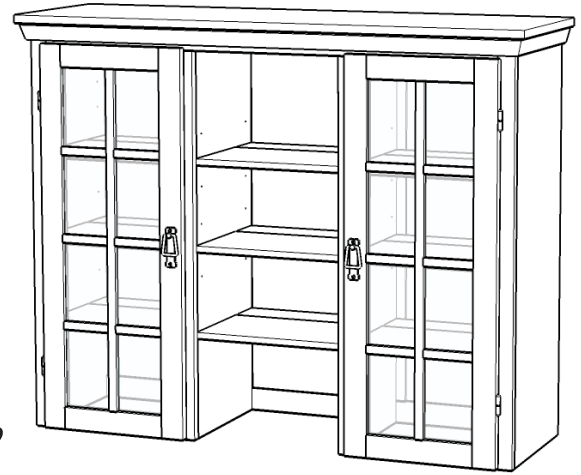

IMPORTANT NOTE

Carefully remove all the parts from the carton and put them individually on a soft cloth to prevent scratches or other damages occurring to the wood parts.

We have taken great care in the design of this product and request that you carefully and strictly follow our assembly instructions to ensure a completed product as it was designed.

Home Styles

Hutch Unit Part List

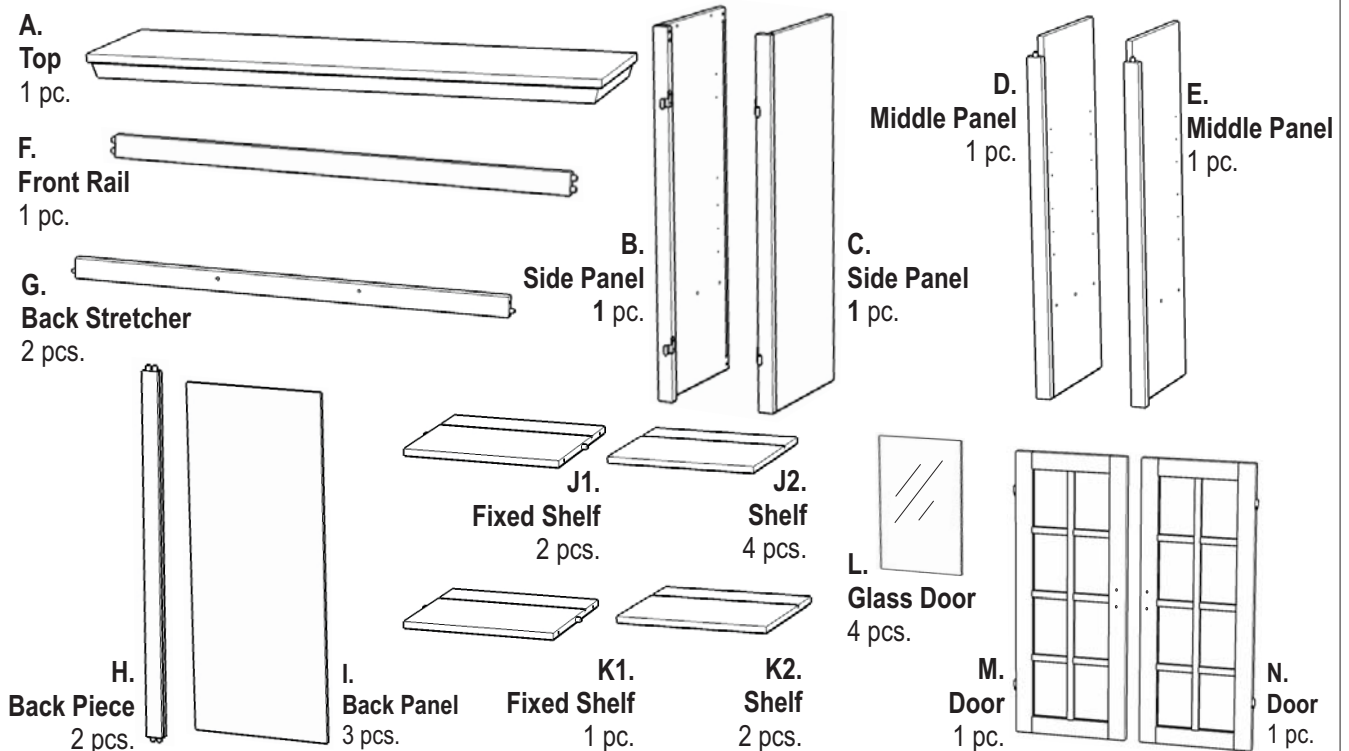

Hardware List

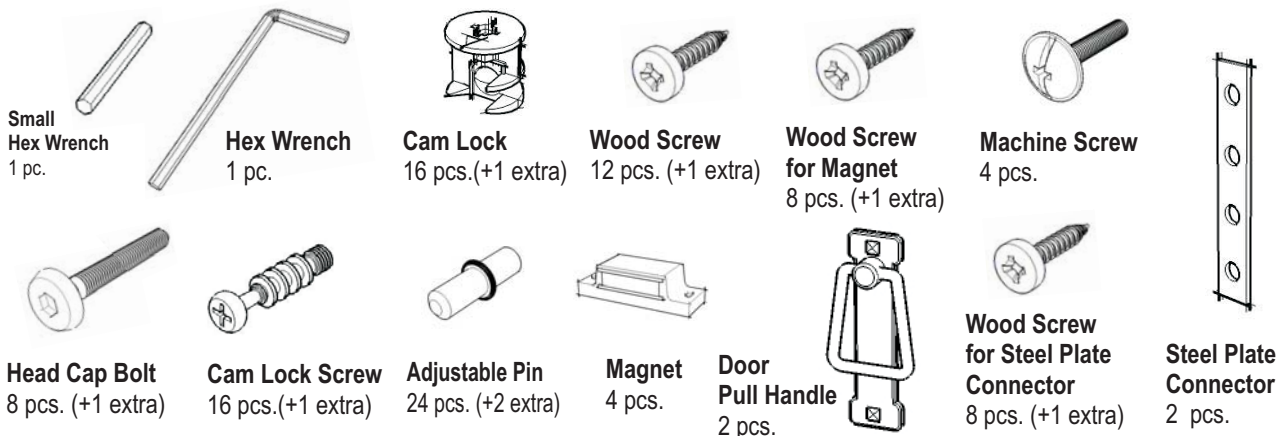

Tools required for assembly : **Phillips** screwdriver

Home Styles Consumer Assistance Line 888-680-7460 and 877-831-0319
servicedesk@homestyles-furniture.com

IMPORTANT

Do not tighten up all the screws until each part is properly assembled.

You should keep Hex Wrench in the safe place as you may need to tighten up the Head Cap Bolts in the future.

STEP 1

Put Cam Lock Screws into the pre-drilled holes of Side Panel (B),(C), Middle Panel (D),(E) and tighten.

Remove Wood Screw from Door (M) and (N).

Slide Glass (L) into the door frame as shown Tighten Wood Screws .

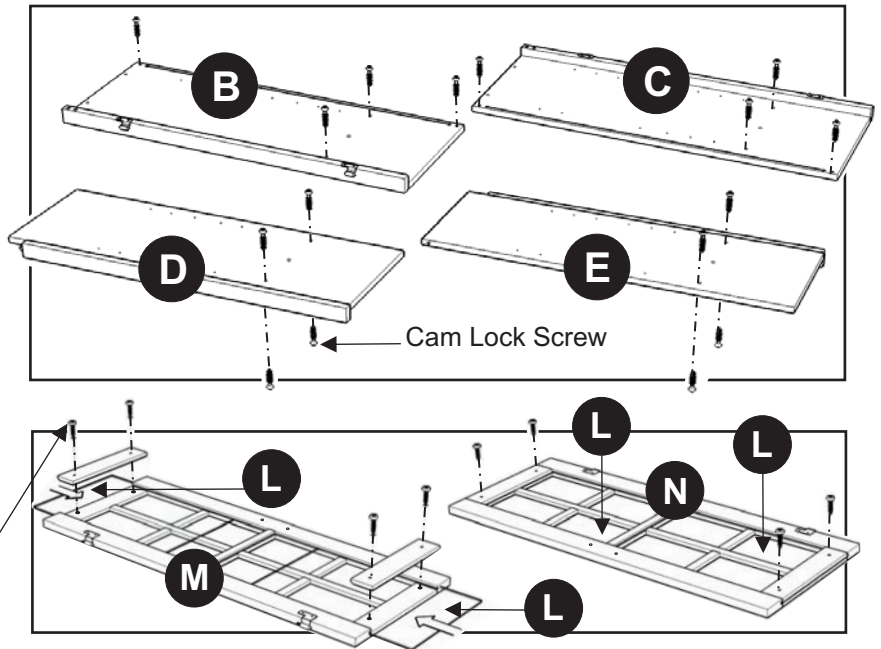

STEP 2

Attach Back Stretcher (G) to Side Panel (B) with Cam Lock.

Attach Back Piece (H) to Back Stretcher (G) and slide Back Panel (I) into place.

Attach second Back Stretcher (G) to the unit with Cam Locks.

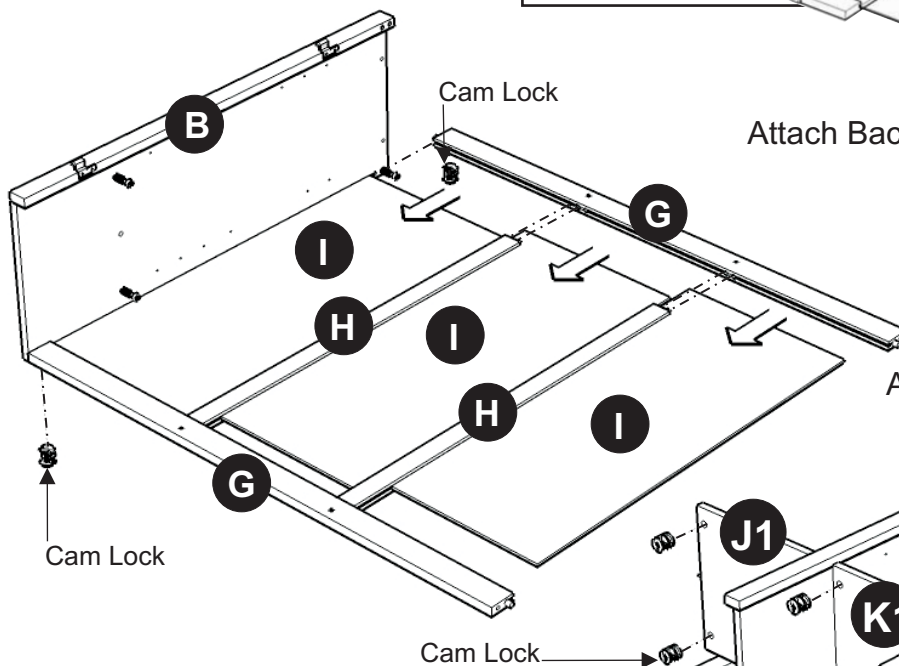

STEP 3

Assemble Fixed Shelf (J1),(K1) Middle Panel (D) and (E) using Cam Locks.

Attach assembled part to the unit with Head Cap Bolts and Cam Locks.

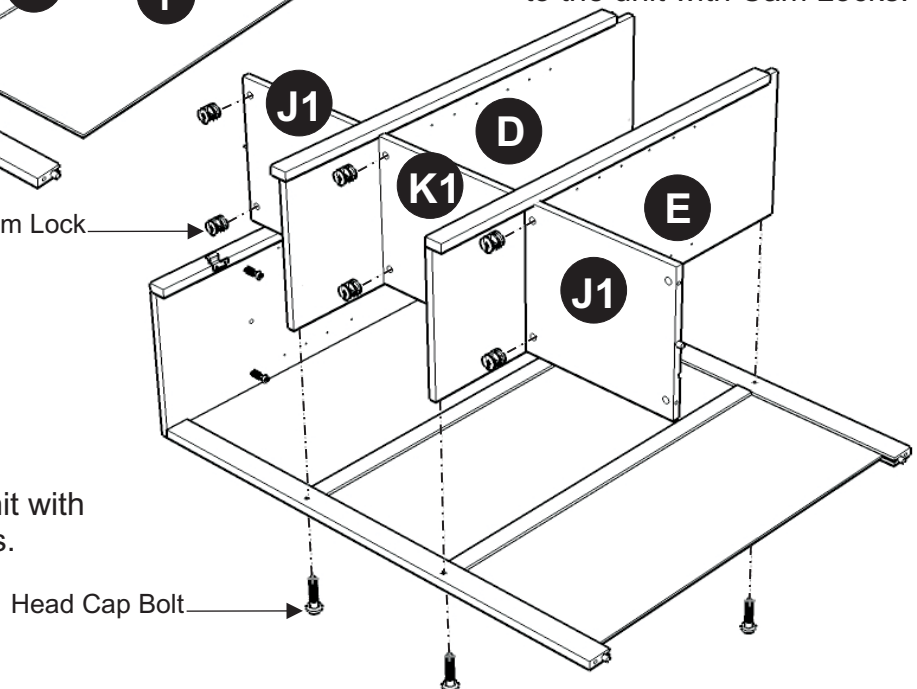

STEP 4

Attach Front Rail (F) to the unit.

Attach Side Panel (C) to the unit with Cam Locks.

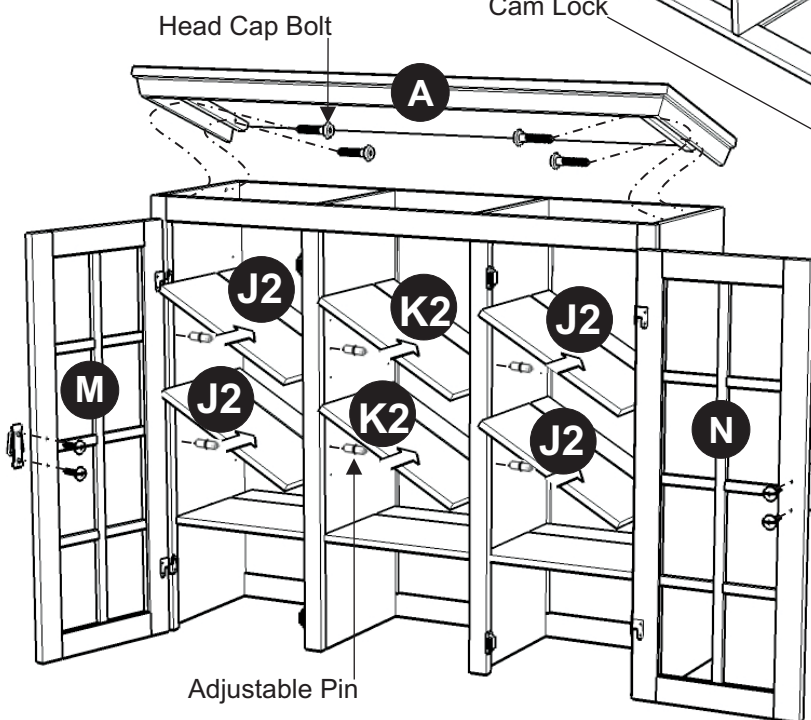
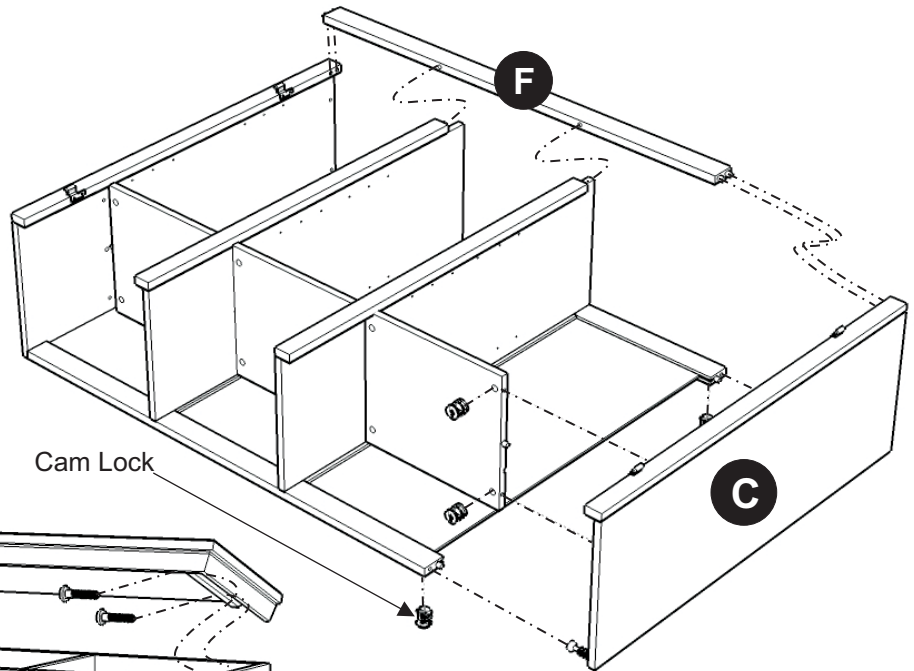

STEP 5

Turn the unit to its upright position.

Insert Adjustable Pins into side panels and middle panels at the desired level. Slide Shelf (J2) and (K2) into place.

Assemble Pull Handles to Door (M) and (N) with Machine Screws. (see Figure 1)

Attach Door (M) and (N) to the side panels by sliding the door lift hinges into the side panel lift hinges. (see Figure 2)

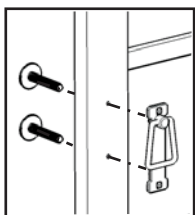

(Figure 1)

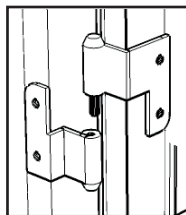

(Figure 2)

Place Top (A) onto the unit with Head Cap Bolts.

Wood Screw

Wood Screw

Steel Plate Connector

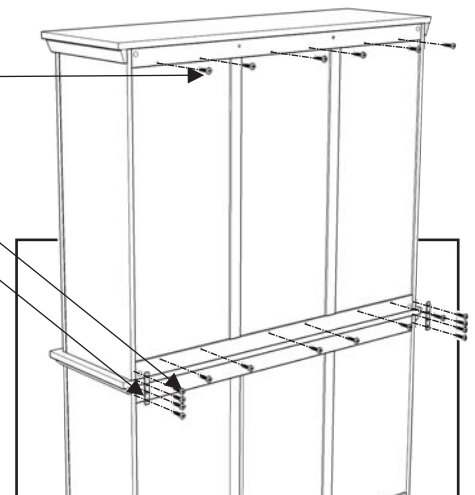

STEP 6

Insert Wood Screws from the back and tighten.

Place the Hutch unit onto the Buffet unit.

Attach Steel Plate Connectors by inserting Wood Screws and tighten. (see Figure 3)

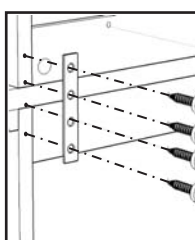

(Figure 3)

Attention !

For safety reasons, please follow these additional instructions to prevent the unit from tipping over.

HARDWARE LIST

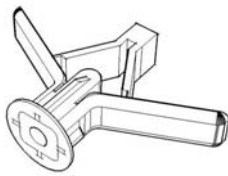

Anchor
2 pcs.(+1 extra)

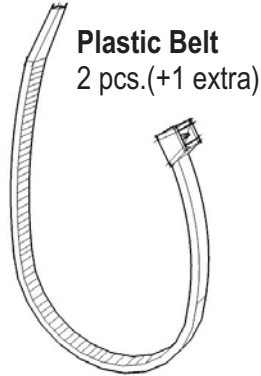

Plastic Belt
2 pcs.(+1 extra)

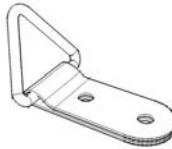

Bracket
4 pcs.(+1 extra)

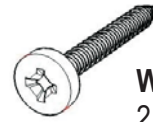

Wall Screw (long)
2 pcs.(+1 extra)



Wood Screw (short)
2 pcs.(+1 extra)

Assembly Instructions

Place the unit at desired location in room.

Drill two ¼" holes in wall at the appropriate location.
Insert the Anchors into the wall holes and attach the Brackets using Wall Screws.

Attach the Brackets at the pre-drilled holes on the top of the unit using Wood Screws.

Use the Plastic Belt to secure the Brackets on the unit to the Brackets on the wall (See figure X).

Put the tie end of the belt into the loop end of the belt and pull until tight.

