

# 88 5531 952 Bedford Kitchen Cart

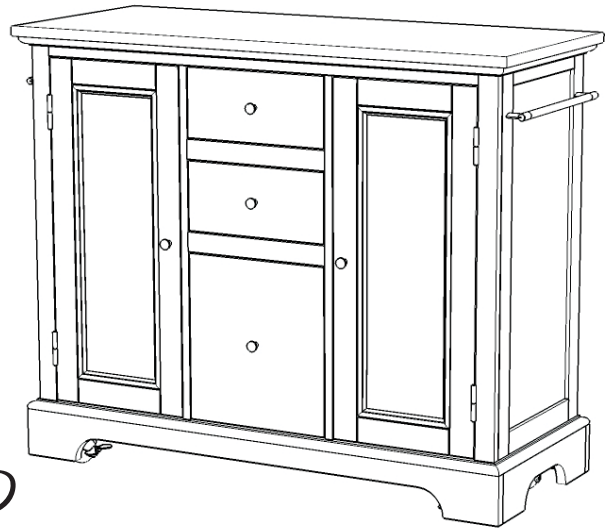

## IMPORTANT NOTE

Carefully remove all the parts from the carton and put them individually on a soft cloth to prevent scratches or other damages occurring to the wood parts.

We have taken great care in the design of this product and request that you carefully and strictly follow our assembly instructions to ensure a completed product as it was designed.



Casual Attire For Today's Home

## PART LIST

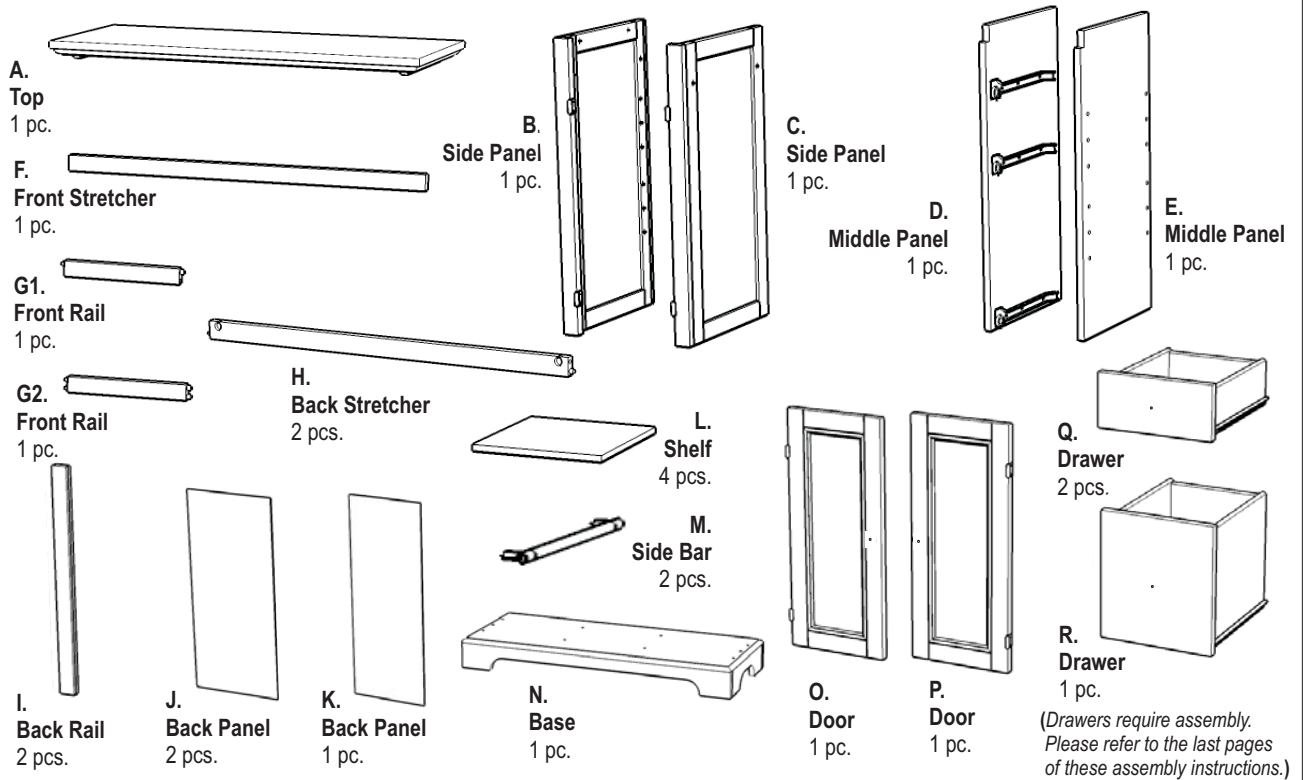

## HARDWARE LIST

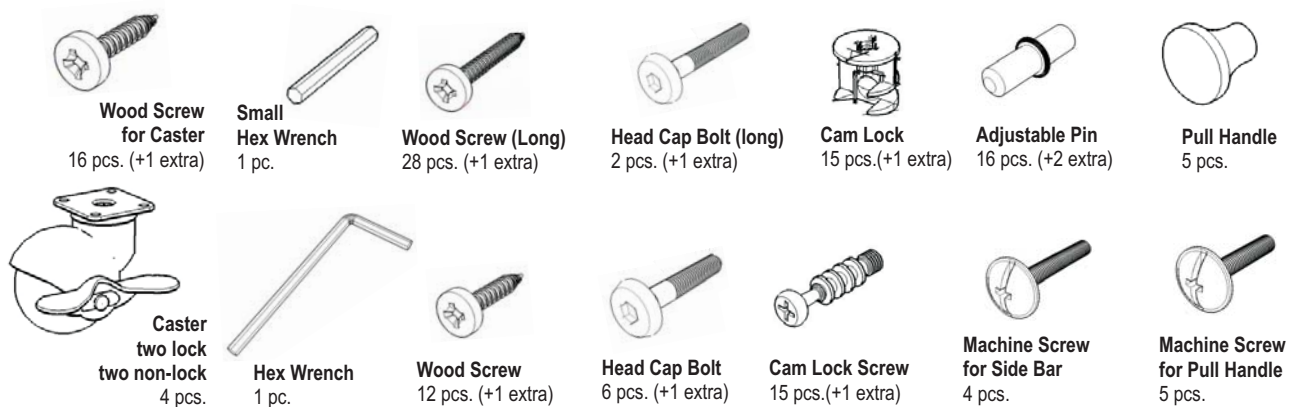

Tools Required For Assembly : **Phillips** screwdriver

**Home Styles Consumer Assistance Line 888-680-7460 and 877-831-0319**  
**servicedesk@homestyles-furniture.com**

**IMPORTANT**

Do not tighten screws until each part is properly assembled.

You should keep Hex Wrench in a safe place as you may need to tighten up the Head Cap Bolts in the future.

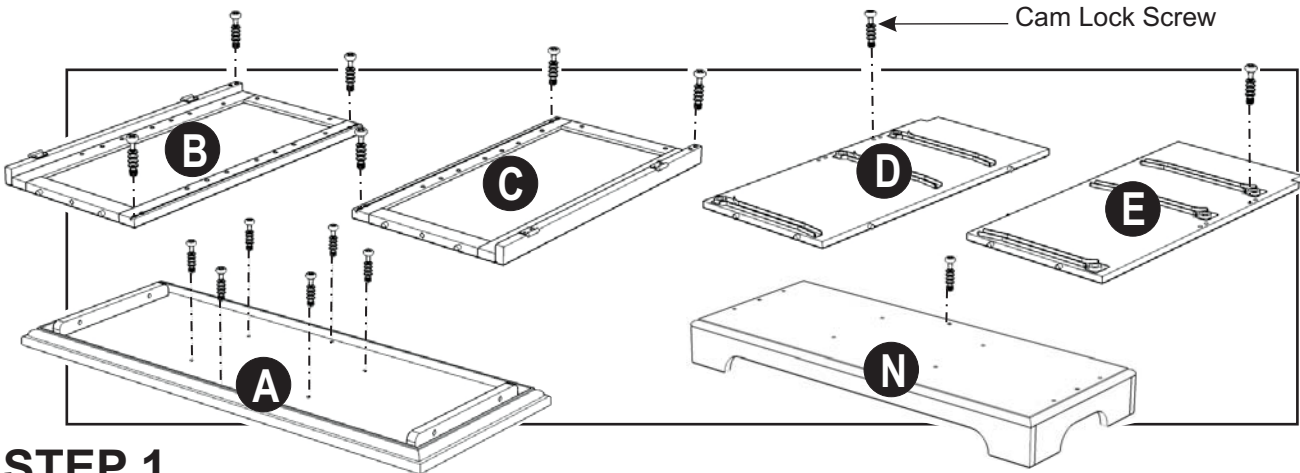

## STEP 1

Put Cam Lock Screws into the pre-drilled holes of Top (A), Side Panel (B), (C), Middle Panel (D), (E), Base (N) and tighten.

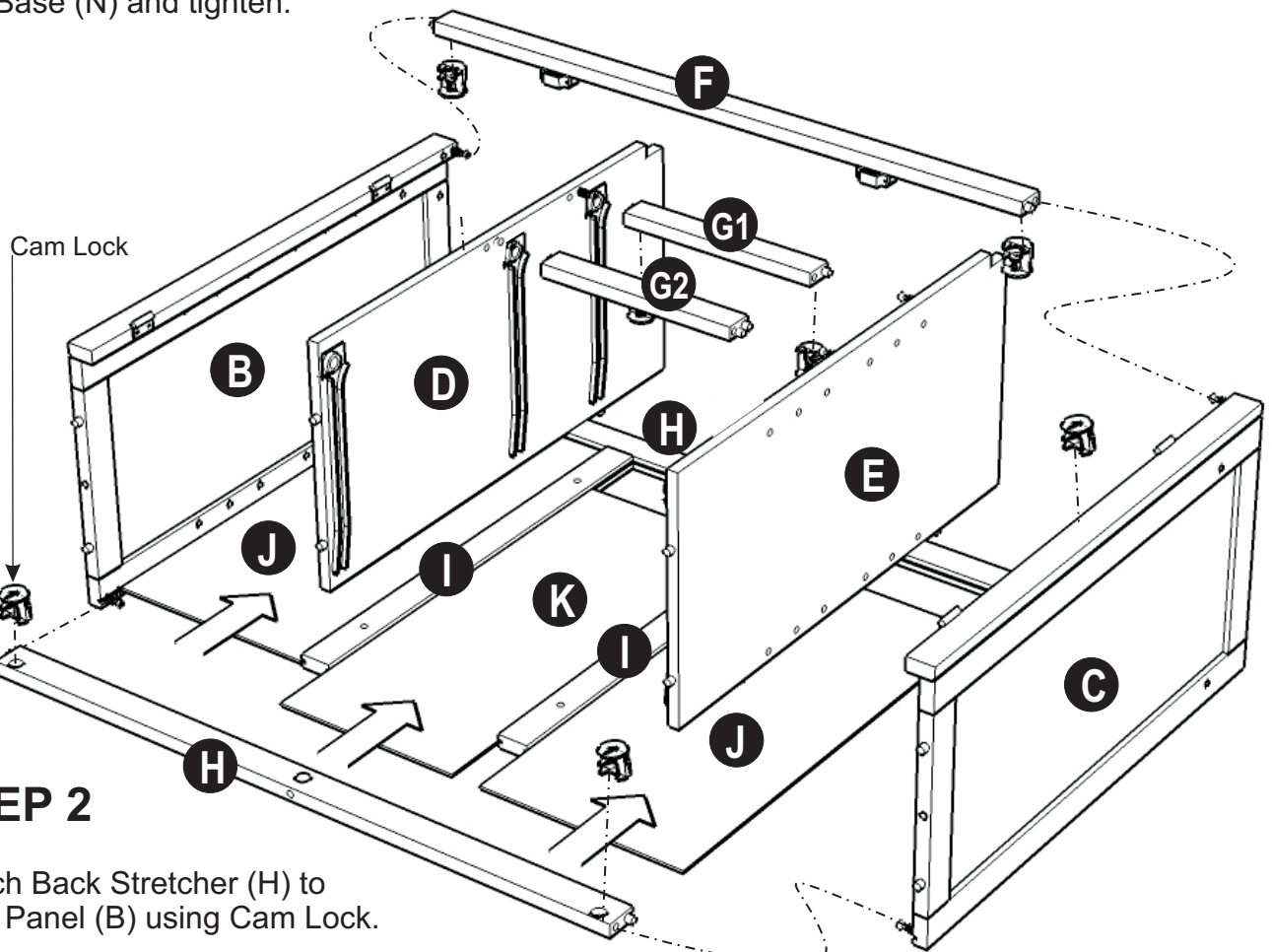

## STEP 2

Attach Back Stretcher (H) to Side Panel (B) using Cam Lock.

Attach Back Rails (I) to the unit and slide Back Panels (J) and (K) into position.

Attach Back Stretcher (H) to unit using Cam Lock.

Assemble Middle Panel (D), (E) and Front Rail (G1), (G2) using Cam Locks, then attach to unit.

Attach Front Stretcher (F) and Side Panel (C) to unit using Cam Locks.

## STEP 3

Attach Base (N) to unit with Head Cap Bolts, Head Cap Bolts (long) and Cam Lock.

Attach the four Castors to the pre drilled holes of legs as shown.

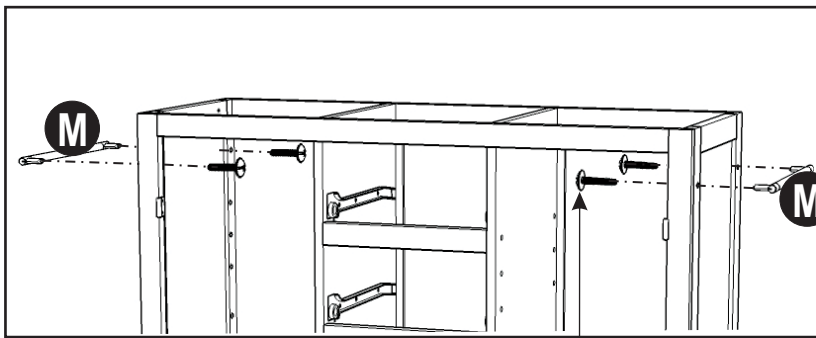
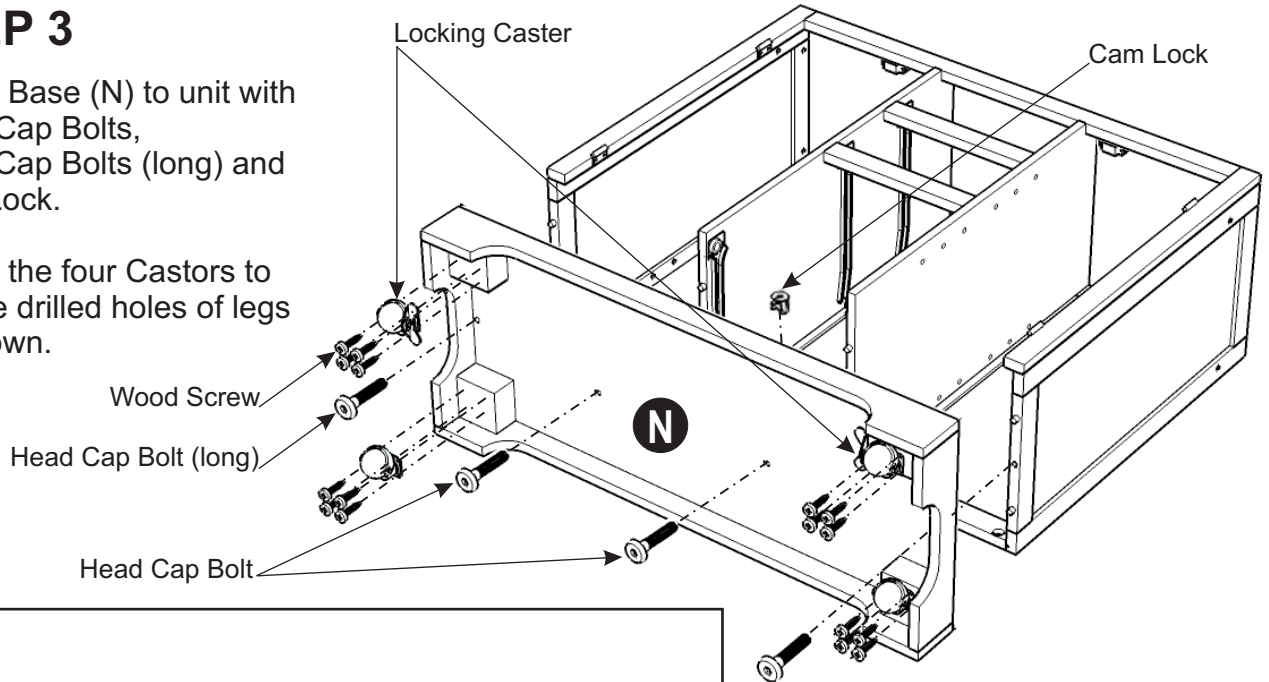

Figure 1

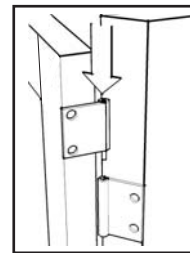

Figure 2

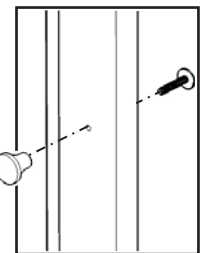

Figure 3

## STEP 4

Machine Screw for Side Bar

Attach Side Bars (M) to unit with Machine Screws. (see Figure 1)

Place Top (A) onto the unit with Head Cap Bolts and Cam Locks.

Attach Door (O) and (P) to the side panels by sliding the door lift hinges into the side panel hinges. (see Figure 2)

Assemble Pull Handles to Door (O) and (P) with Machine Screws. (see Figure 3)

Insert Adjustable Pins into side panels and middle panels at the desired level.

Slide Shelf (L) into place.

Slide the Drawer (Q) and (R) into position.

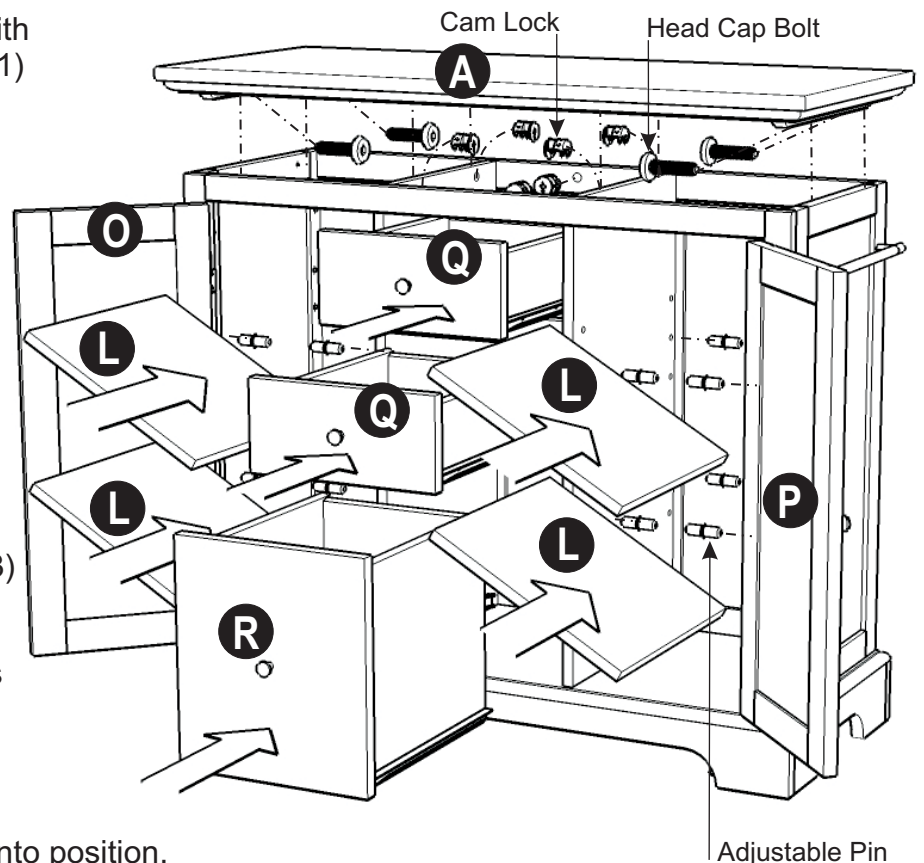

Adjustable Pin

## Drawer (Q)

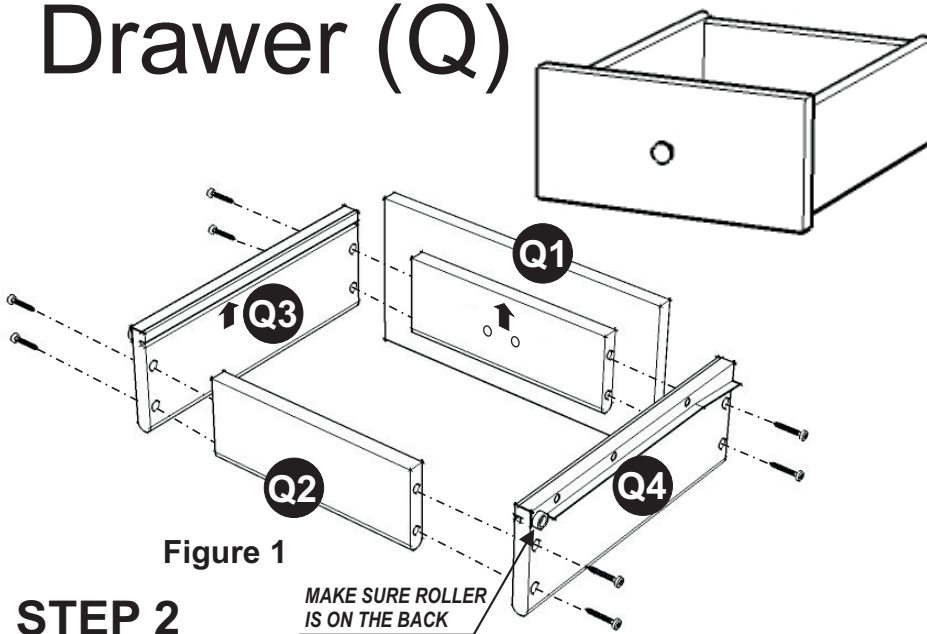

Figure 1

### STEP 1

Attach Q1 to Q3 and Q4, using a Phillips screwdriver and long wood screws (4X), tighten halfway.

Attach Q2 to Q3 and Q4 using long wood screws (4X), tighten halfway. (see Figure 1)

### STEP 2

Slide Q5 into the grooves in Q3 and Q4. Be sure to push Q5 all the way forward so it meets Q1. (see Figure 2)

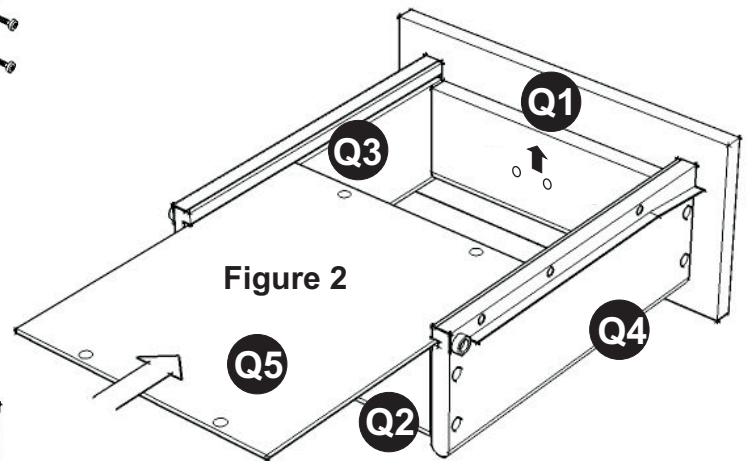

Figure 2

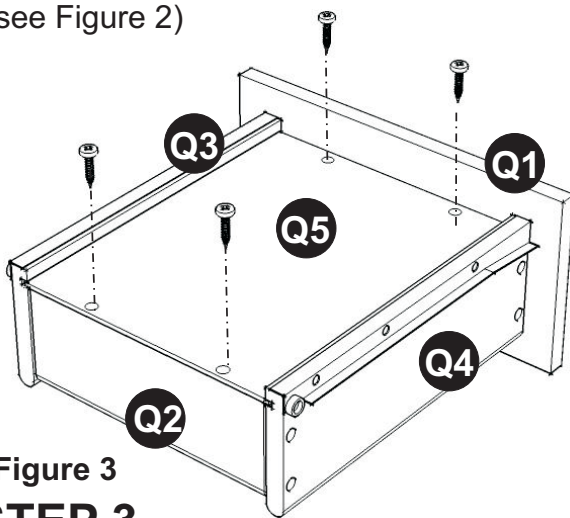

Figure 3

### STEP 3

Insert short wood screws (4X) into the pre-drilled holes in Q5, tighten screws. (see Figure 3)

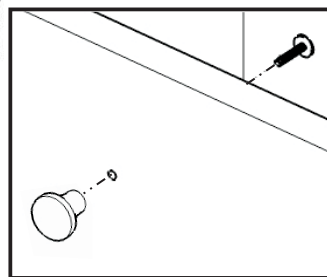

Figure 4

### STEP 4

Attach hardware pulls with machine screws. (see Figure 4)

Tighten all screws used in drawer assembly.

## Part List

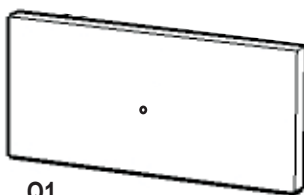

**Q1.**  
Front Part  
2 pcs.



**Q2.**  
Back Part  
2 pcs.

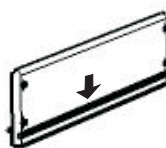

**Q3.**  
Side Part  
2 pcs.



**Q4.**  
Side Part  
2 pcs.



**Q5.**  
Base Part  
2 pcs.

# Drawer (R)

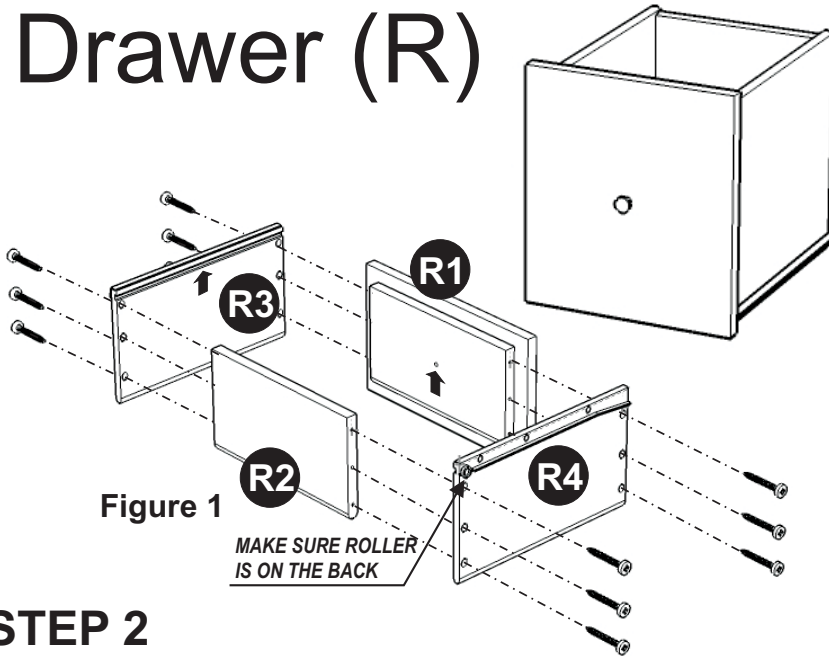

Figure 1

MAKE SURE ROLLER IS ON THE BACK

## STEP 1

Attach R1 to R3 and R4, using a Phillips screwdriver and long wood screws (6X), tighten halfway.

Attach R2 to R3 and R4 using long wood screws (6X), tighten halfway. (see Figure 1)

## STEP 2

Slide R5 into the grooves in R3 and R4. Be sure to push R5 all the way forward so it meets R1. (see Figure 2)

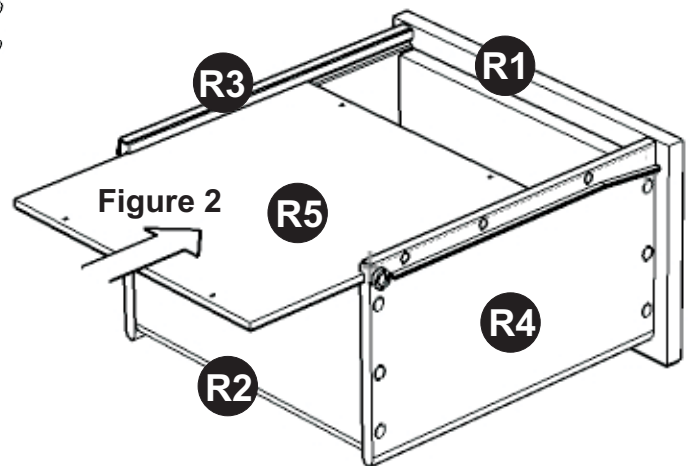

Figure 2

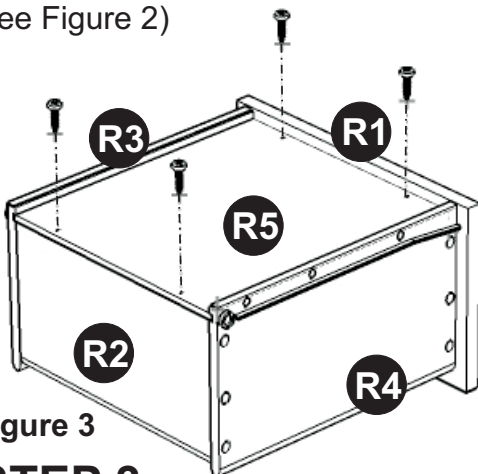

Figure 3

## STEP 3

Insert short wood screws (4X) into the pre-drilled holes in R5, tighten screws. (see Figure 3)

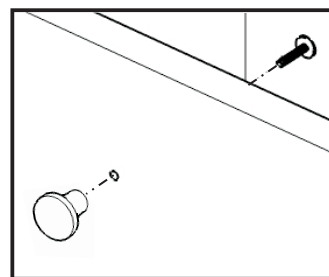

Figure 4

## STEP 4

Attach hardware pulls with machine screws. (see Figure 4)

**Tighten all screws used in drawer assembly.**

## Part List

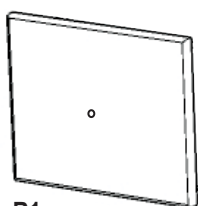

R1.  
Front Part  
1 pc.

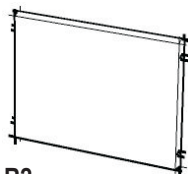

R2.  
Back Part  
1 pc.

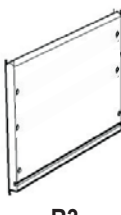

R3.  
Side Part  
1 pc.



R4.  
Side Part  
1 pc.

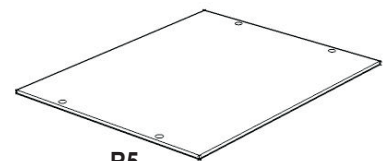

R5.  
Base Part  
1 pc.