

# 88 5541 19 Windsor Computer Base (Windsor Finish)

## IMPORTANT NOTE

Carefully remove all the parts from the carton and put them individually on a soft cloth to prevent scratches or other damages occurring to the wood parts.

We have taken great care in the design of this product and request that you carefully and strictly follow our assembly instructions to ensure a completed product as it was designed.

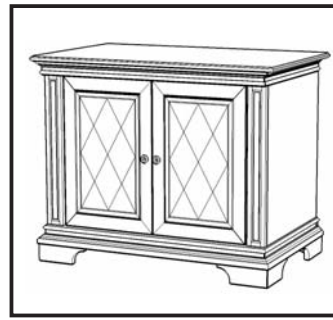

Base Unit

Home  
Styles

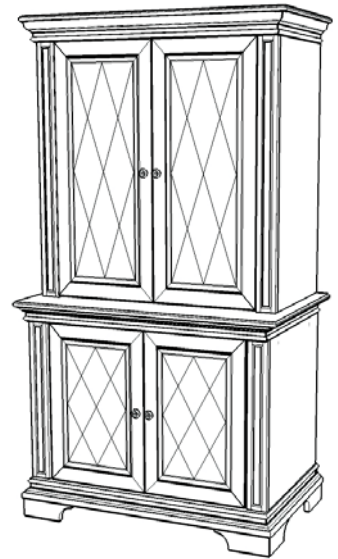

## Part List

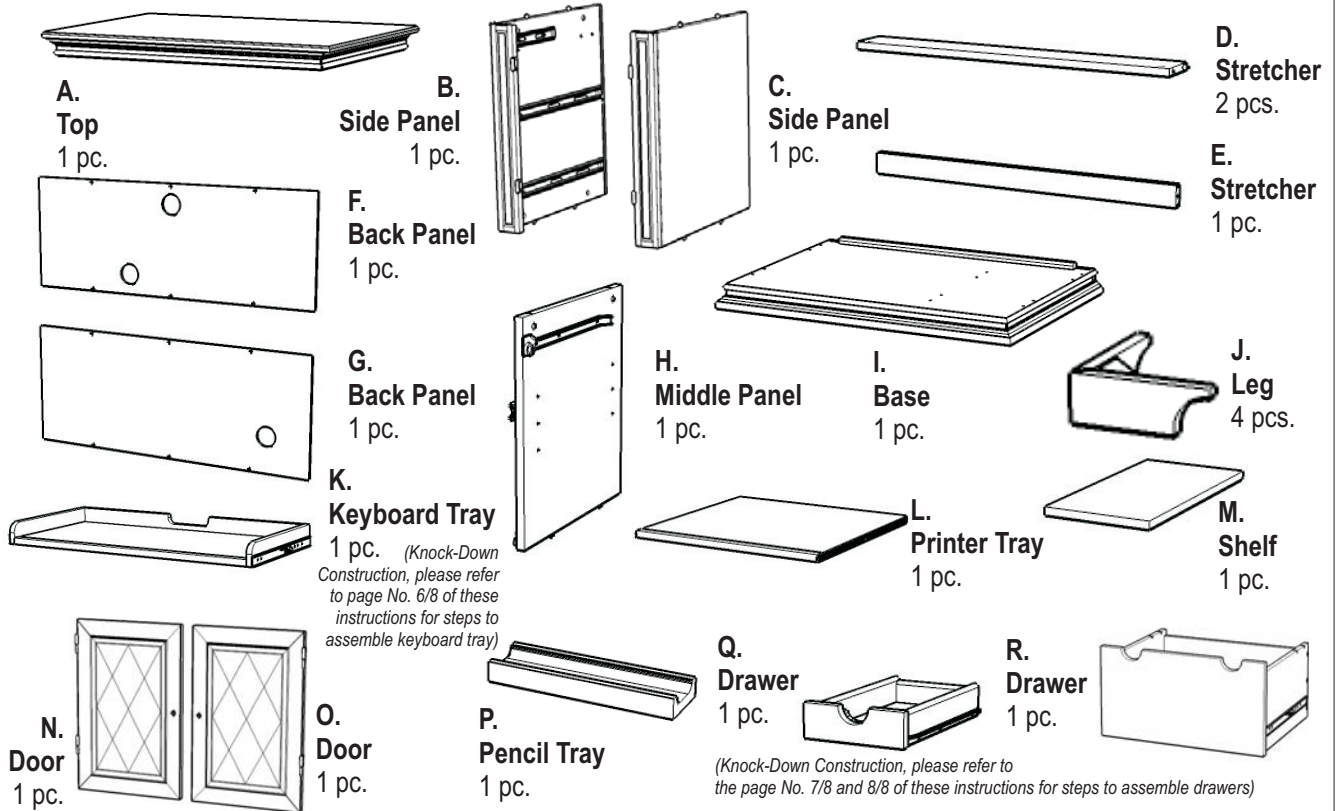

## Hardware List



Tools required for assembly : **Phillips** screwdriver

Tools recommended for assembly : Level

Home Styles Consumer Assistance Line 888-680-7460 and 877-831-0319

[servicedesk@homestyles-furniture.com](mailto:servicedesk@homestyles-furniture.com)

# Assembly Instructions 2/8

## IMPORTANT

- \* Do not tighten up all the screws until each part is properly assembled.
- \* You should keep Hex Wrench in a safe place as you may need to tighten up the Head Cap Bolts in the future.
- \* After assembly, item must be level to work properly. Use the included adjustable levelers to level.

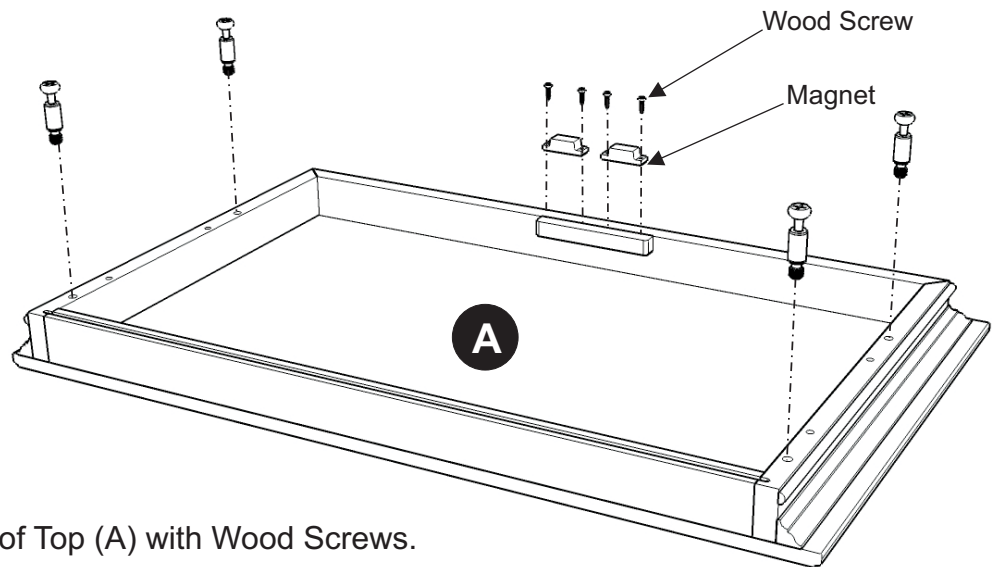

## STEP 1

Attach 2X Magnets to pre-drilled holes of Top (A) with Wood Screws.

Insert Cam Lock Screws into the pre-drilled holes of Top (A), Side Panel (B) and (C).

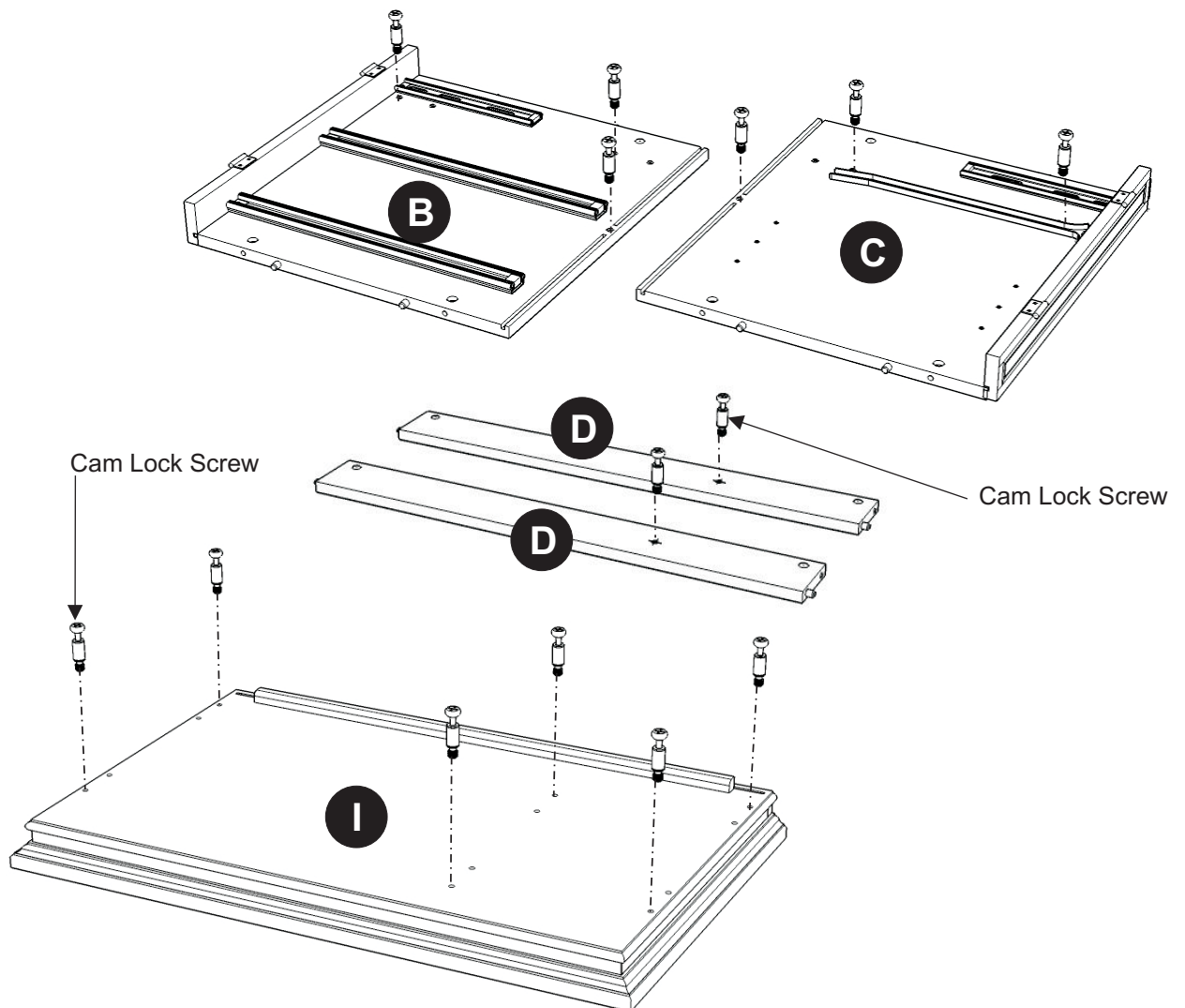

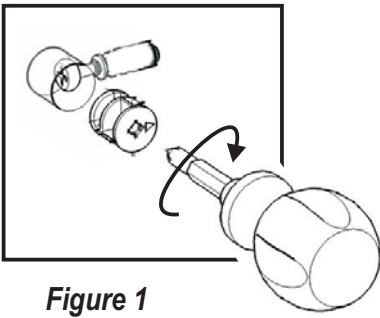
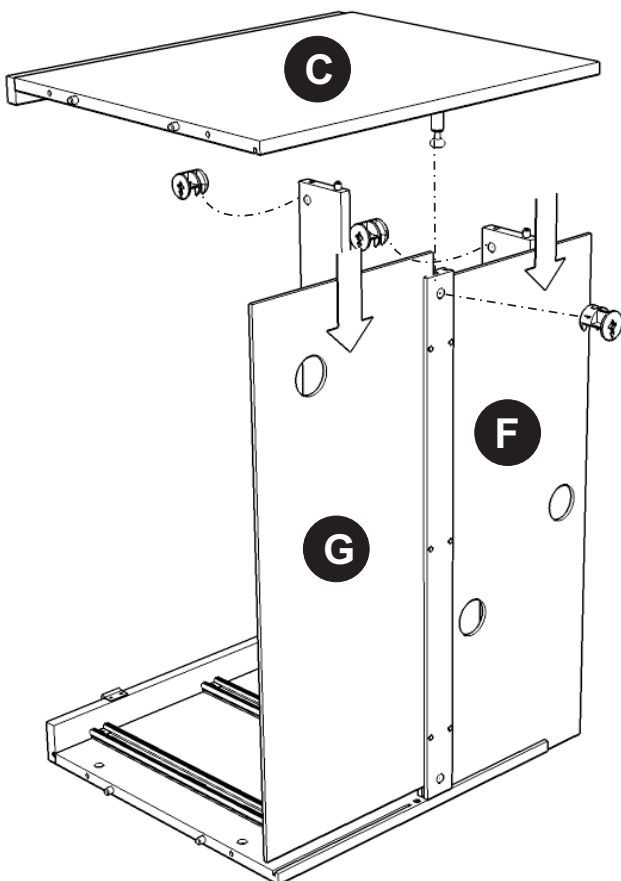
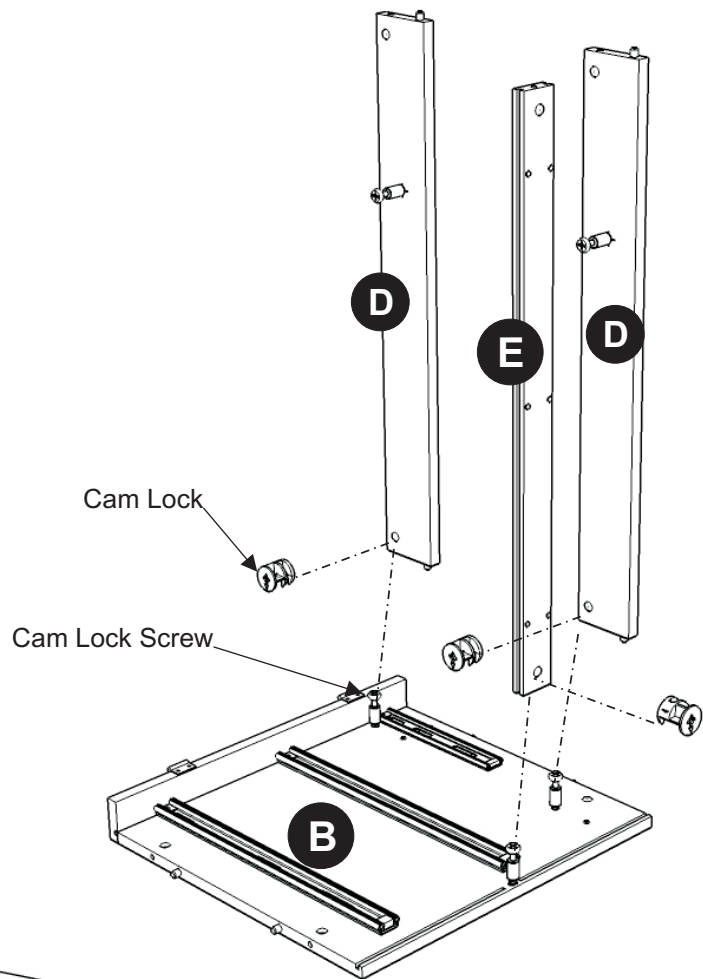

Figure 1

## STEP 2

Attach Stretchers (D) and (E) onto Side Panel (B) with Cam Locks (see Figure 1).



## STEP 3

Slide Back Panel (F) and (G) into the unit.

Attach Side Panel (C) to the unit with Cam Locks.

**STEP 4**

Attach Legs (J) into the pre-drilled holes of Base (I) by using the Head Cap Bolts, Spring Washers and Flat Washers.

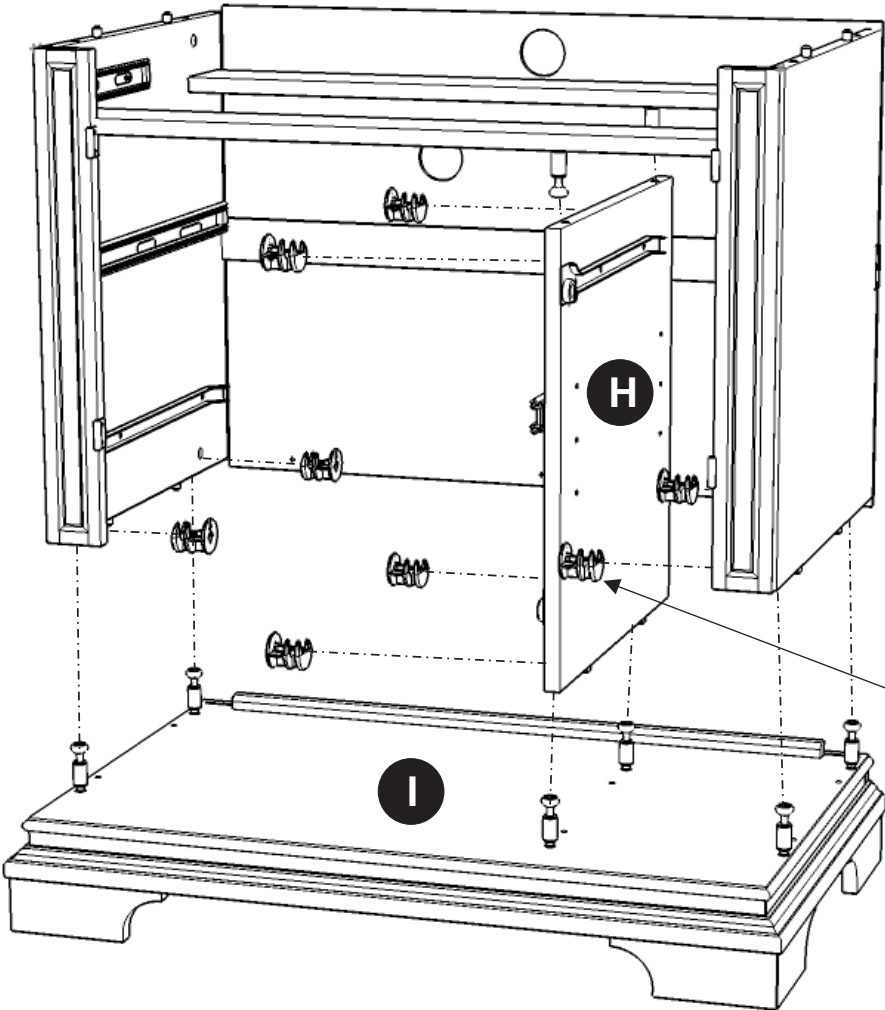
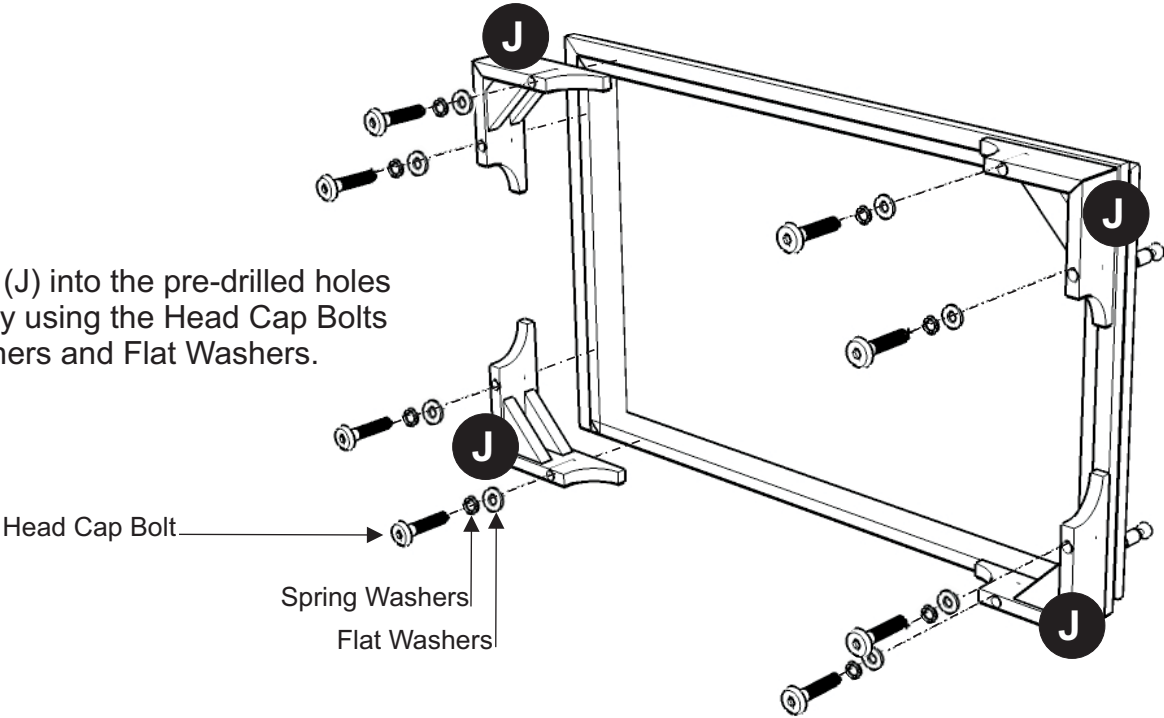

**STEP 5**

Attach Middle Panel (H) to the unit with Cam Locks.

Attach Base (I) to the unit with Cam Locks.

Cam Lock

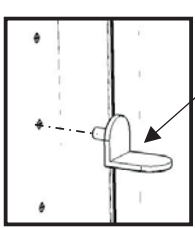

Adjustable Pin

Figure 2

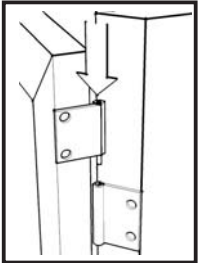

Figure 3

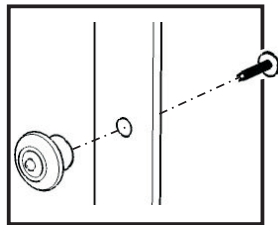
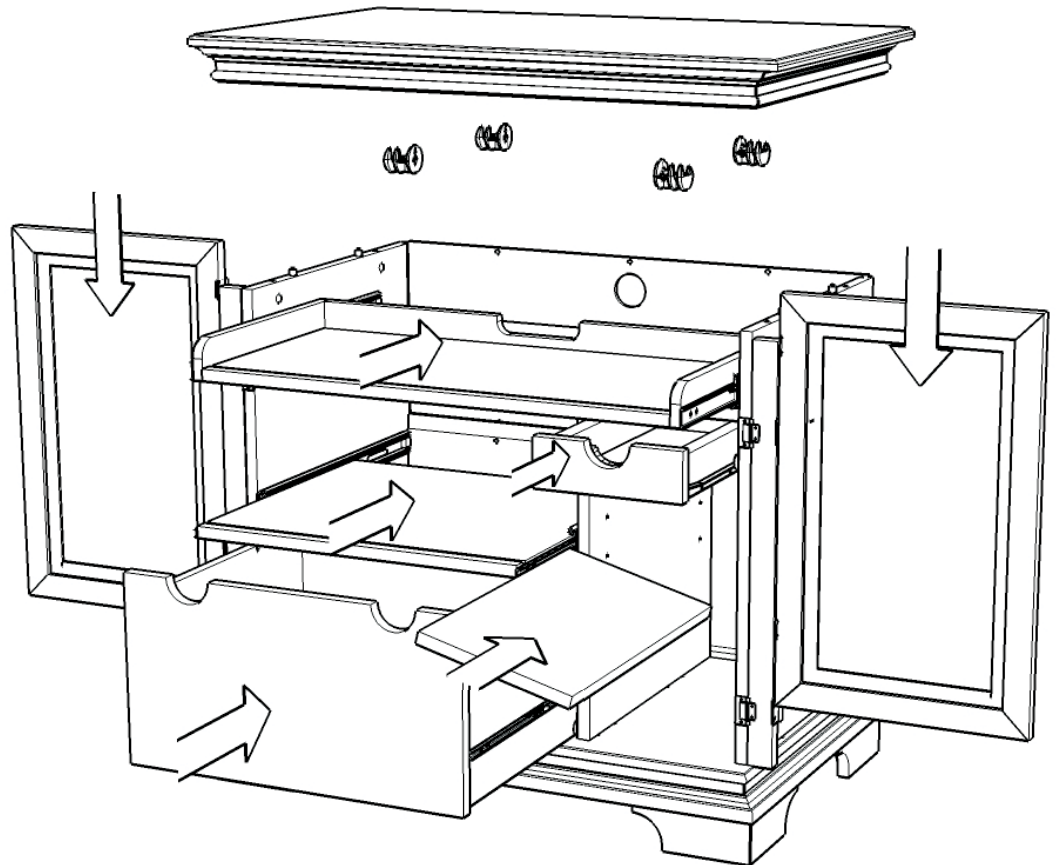

Figure 4



## STEP 5

Place Top (A) onto the unit with Cam Locks.

Slide Keyboard Tray (K), Printer Tray (L), Drawer (P) and (Q) into position.

Insert Adjustable Pins into side panel and middle panel at the desired level (See figure 2), then place Shelf (M) into position.

Attach Doors (N) and (O) by sliding the door lift hinges into the side panels lift hinges (See figure 3).

Assemble Pull Handles to Doors (N) and (O) with Machine Screws. (See figure 4)

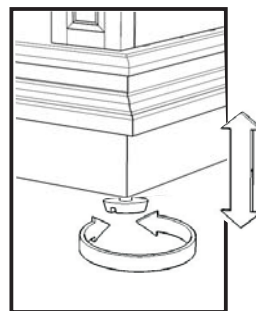
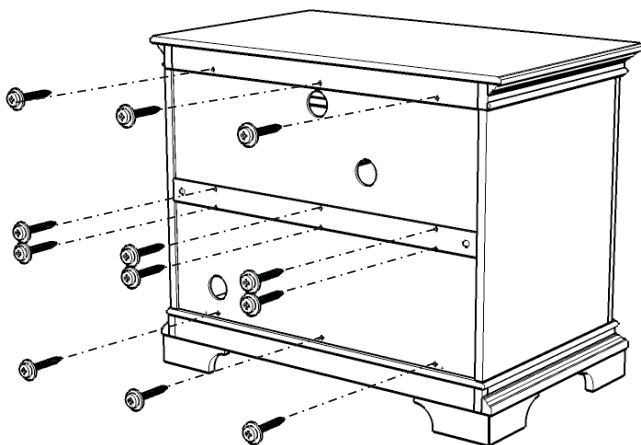

Figure 5

## STEP 6

To level the unit, adjust the adjustable levelers on the bottom of legs. (See figure 5)

Insert 12X Wood Screws from the back of the unit, tighten up all the Wood Screws.

**Note: Please make sure unit is level before tightening these screws.**

# Keyboard Tray (K)

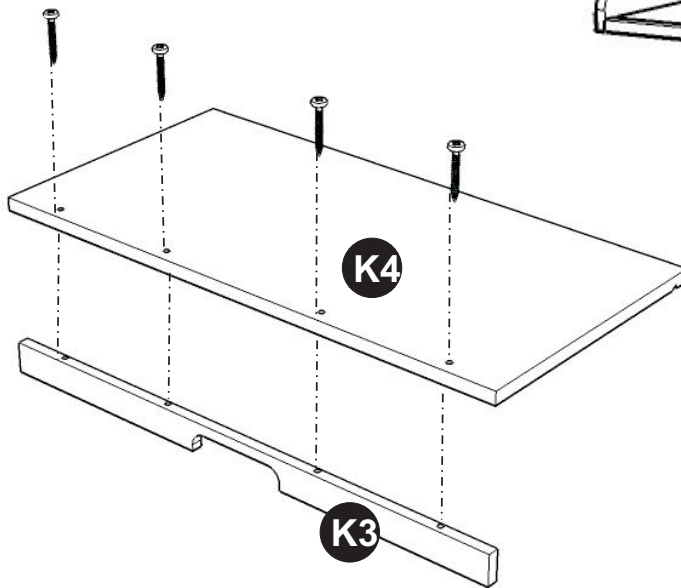
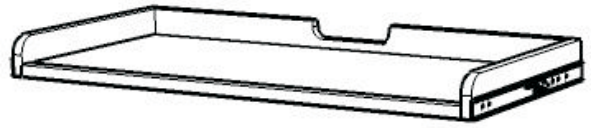

## STEP 1

Attach K3 to K4, using a Phillips screw driver and long wood screws (4X).

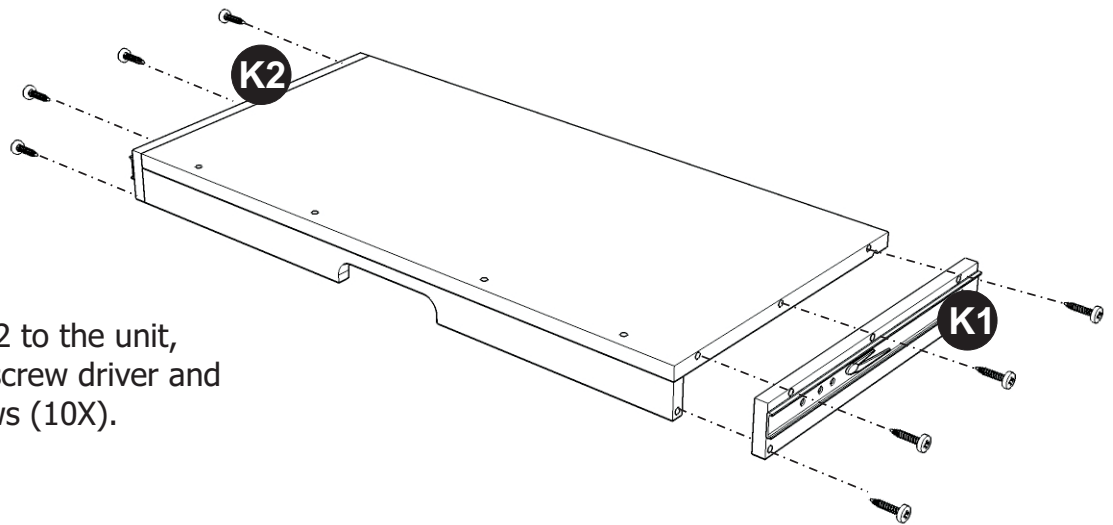

## STEP 2

Attach K1 and K2 to the unit, using a Phillips screw driver and long wood screws (10X).

## Part List

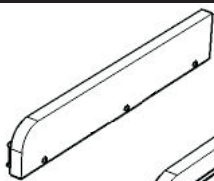

**K1.**  
Side Part  
1 pc.



**K2.**  
Side Part  
1 pc.

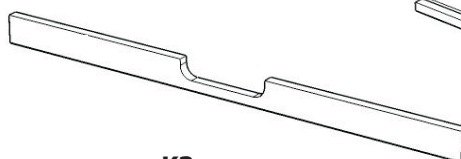

**K3.**  
Back Part  
1 pc.

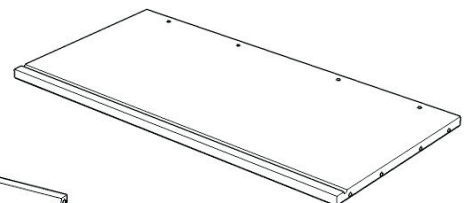

**K4.**  
Base Part  
1 pc.

# Drawer (Q)

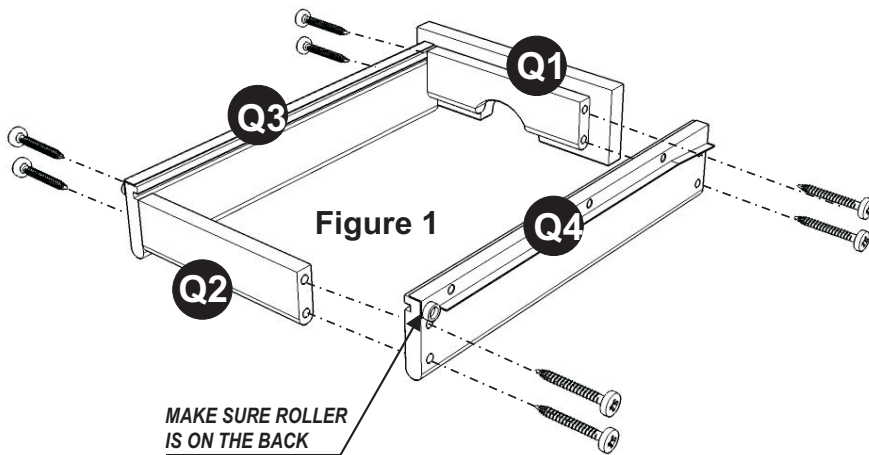

## STEP 1

Attach Q1 to Q3 and Q4, using a Phillips screw driver and long wood screws (4X), tighten halfway.

Attach Q2 to Q3 and Q4 using long wood screws (4X), tighten halfway. (see Figure 1)

## STEP 2

Slide Q5 into the grooves in Q3 and Q4. Be sure to push Q5 all the way forward so it meets Q1. (see Figure 2)

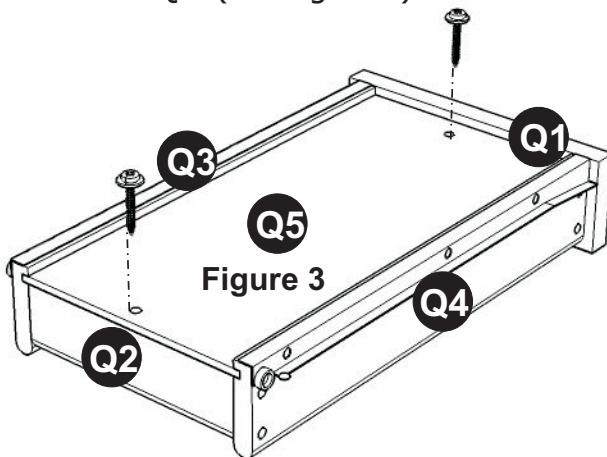
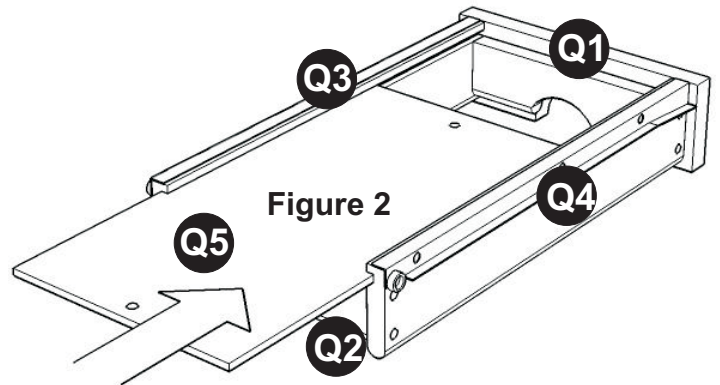

## STEP 3

Insert short wood screws (2X) into the pre-drilled holes in Q5, tighten screws. (see Figure 3)

## STEP 4

Place Pencil Tray (P) into position. (see Figure 4)

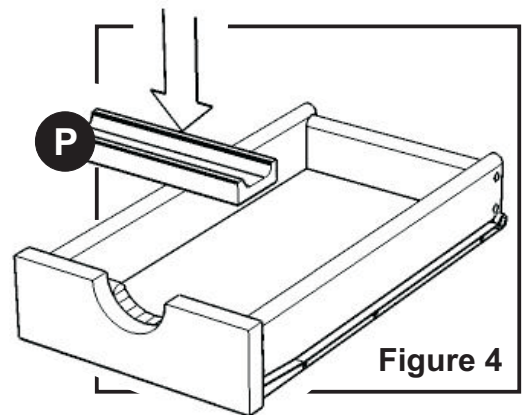

**Tighten all screws used in drawer assembly.**

## Part List

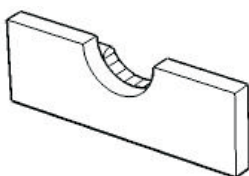

**Q1.**  
Front Part  
1 pc.



**Q2.**  
Back Part  
1 pc.

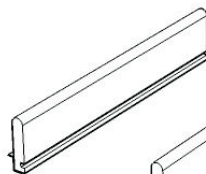

**Q3.**  
Side Part  
1 pc.

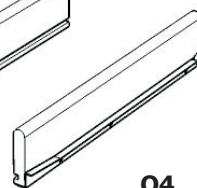

**Q4.**  
Side Part  
1 pc.

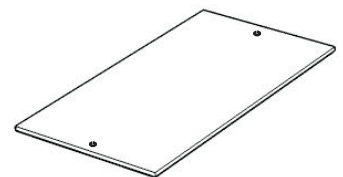

**Q5.**  
Base Part  
1 pc.

# Drawer (R)

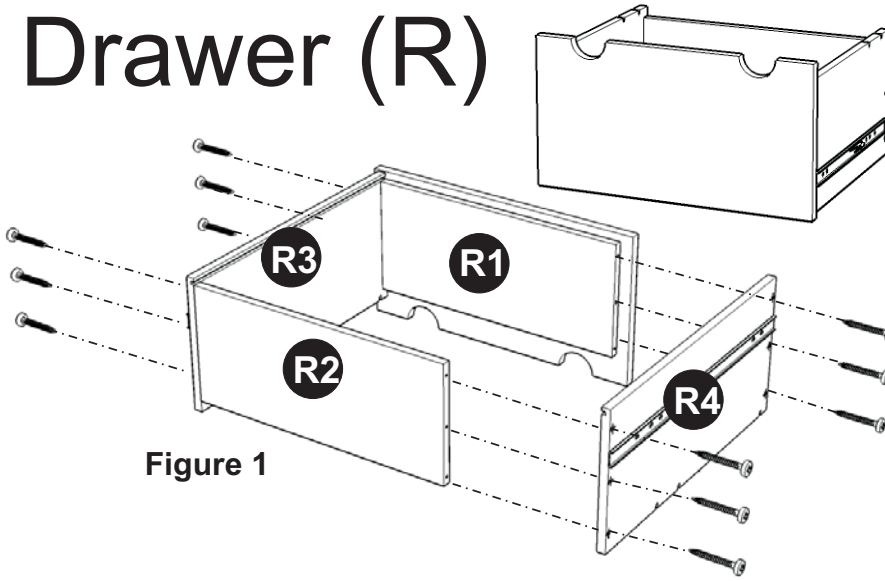

Figure 1

## STEP 1

Attach R1 to R3 and R4, using a Phillips screw driver and long wood screws (6X), tighten halfway.

Attach R2 to R3 and R4 using long wood screws (6X), tighten halfway. (see Figure 1)

## STEP 2

Slide R5 into the grooves in R3 and R4. Be sure to push R5 all the way forward so it meets R1. (see Figure 2)

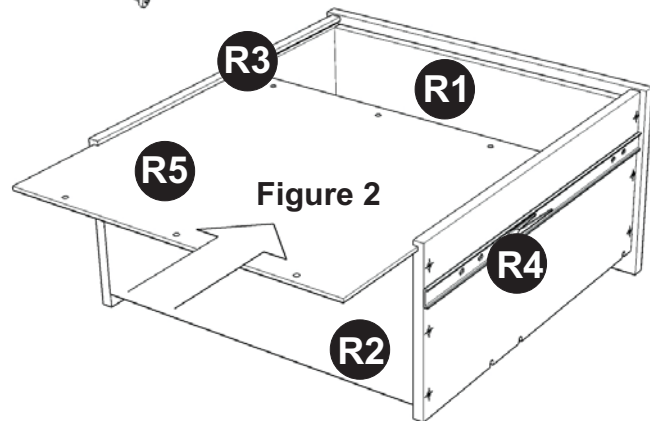

Figure 2

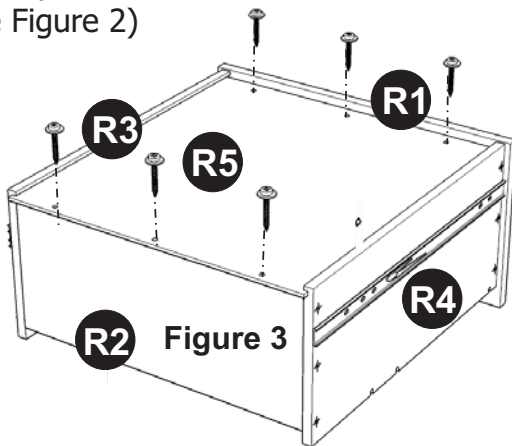

Figure 3

## STEP 3

Insert short wood screws (6X) into the pre-drilled holes in R5, tighten screws. (see Figure 3)

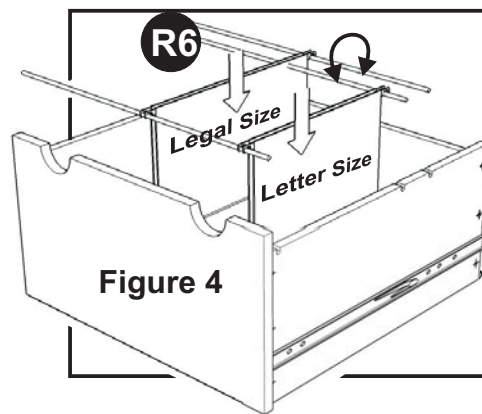

Figure 4

## STEP 4

Remove the tape holding the Metal Strips R6 in place.

You can adjust the Metal Strip for letter size or legal size file as shown.

**Tighten all screws used in drawer assembly.**

## Part List

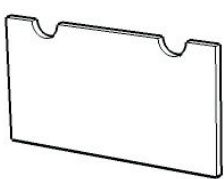

**R1.**  
Front Part  
1 pc.

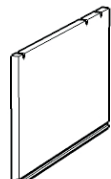

**R2.**  
Back Part  
1 pc.



**R3.**  
Side Part  
1 pc.



**R4.**  
Side Part  
1 pc.



**R5.**  
Base Part  
1 pc.



**R6.**  
Metal Strip  
2 pcs.