

88 5541 194 Windsor Computer Hutch (Windsor Finish)

IMPORTANT NOTE

Carefully remove all the parts from the carton and put them individually on a soft cloth to prevent scratches or other damages occurring to the wood parts.

We have taken great care in the design of this product and request that you carefully and strictly follow our assembly instructions to ensure a completed product as it was designed.

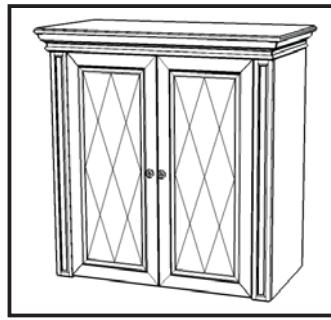

Hutch Unit

Home
Styles

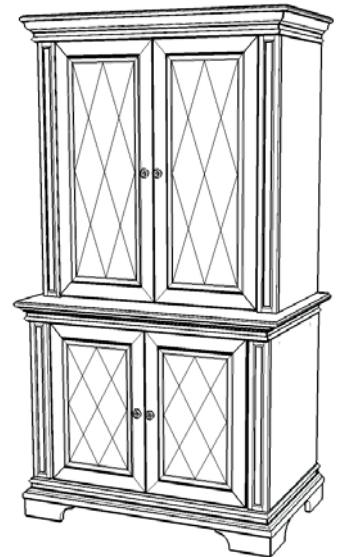

Part List

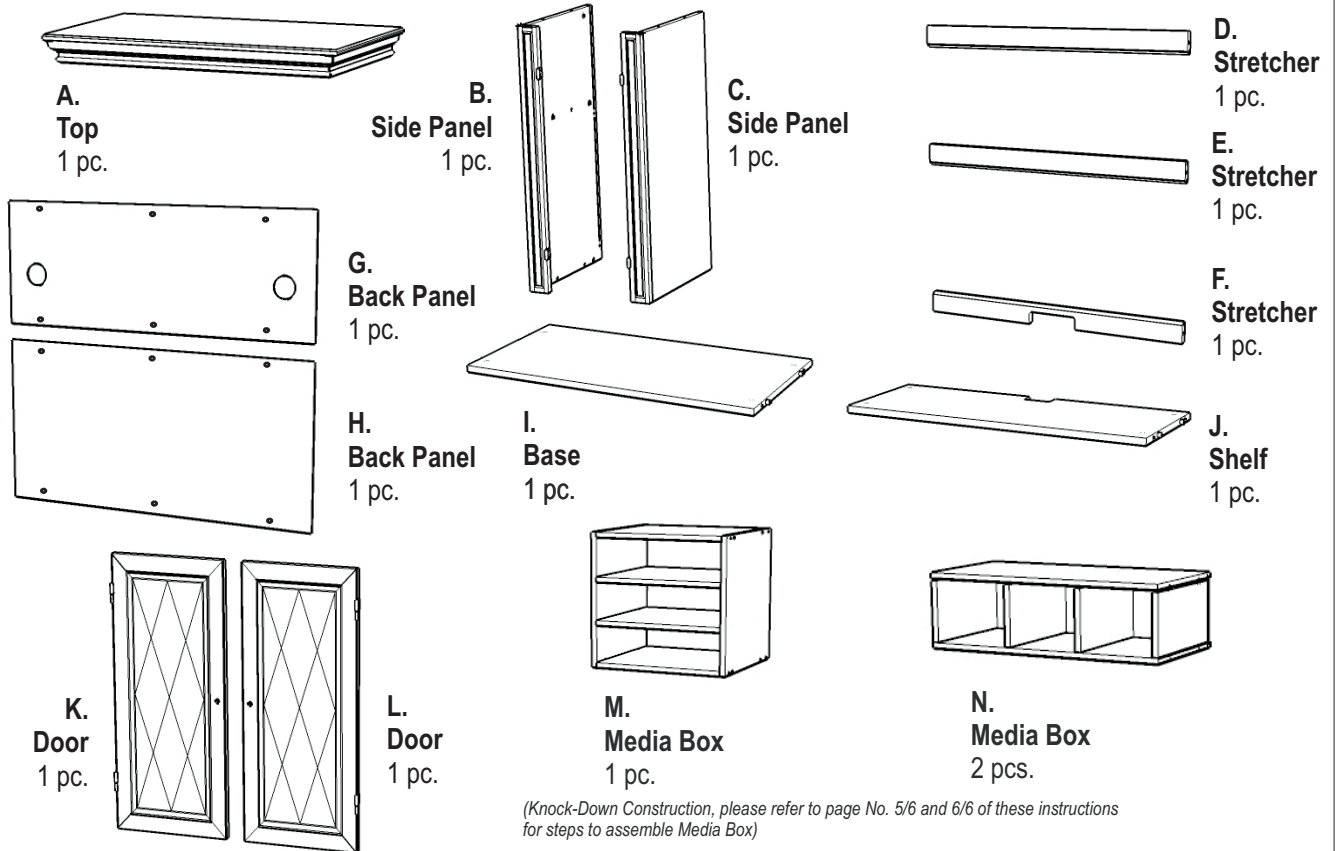

Hardware List



Tools required for assembly : **Phillips** screwdriver

Home Styles Consumer Assistance Line 888-680-7460 and 877-831-0319
servicedesk@homestyles-furniture.com

IMPORTANT

** Do not tighten up all the screws until each part is properly assembled.*

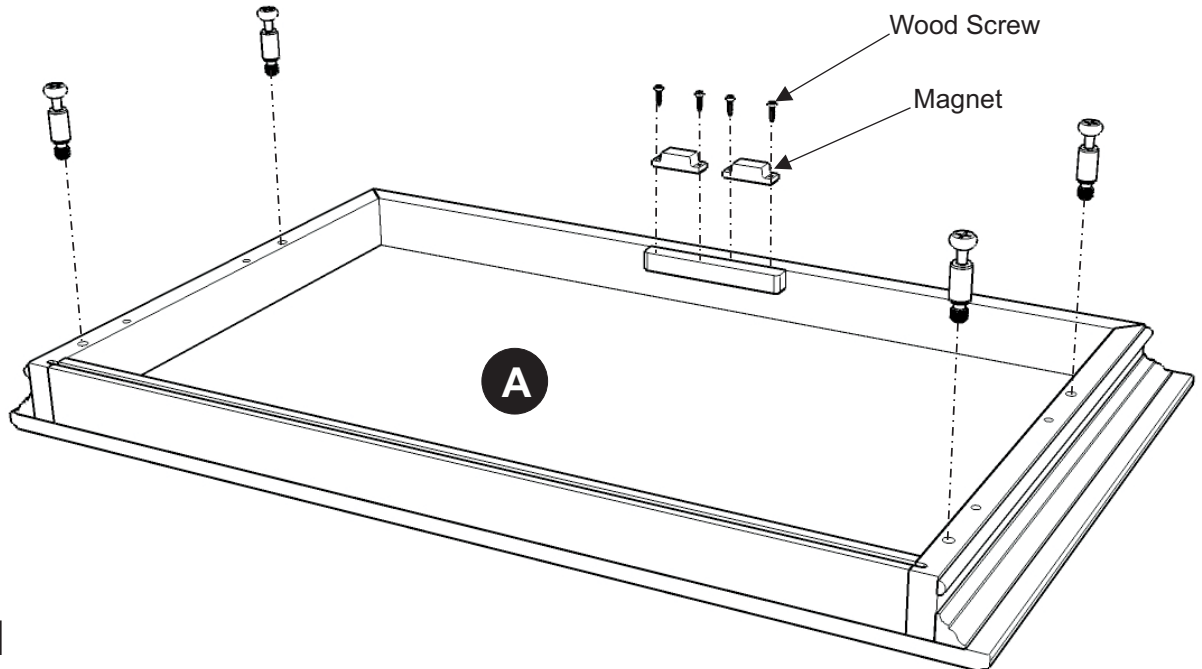

STEP 1

Attach 2X Magnets to pre-drilled holes of Top (A) with Wood Screws.

Insert Cam Lock Screws into the pre-drilled holes of Top (A), Side Panel (B) and (C).

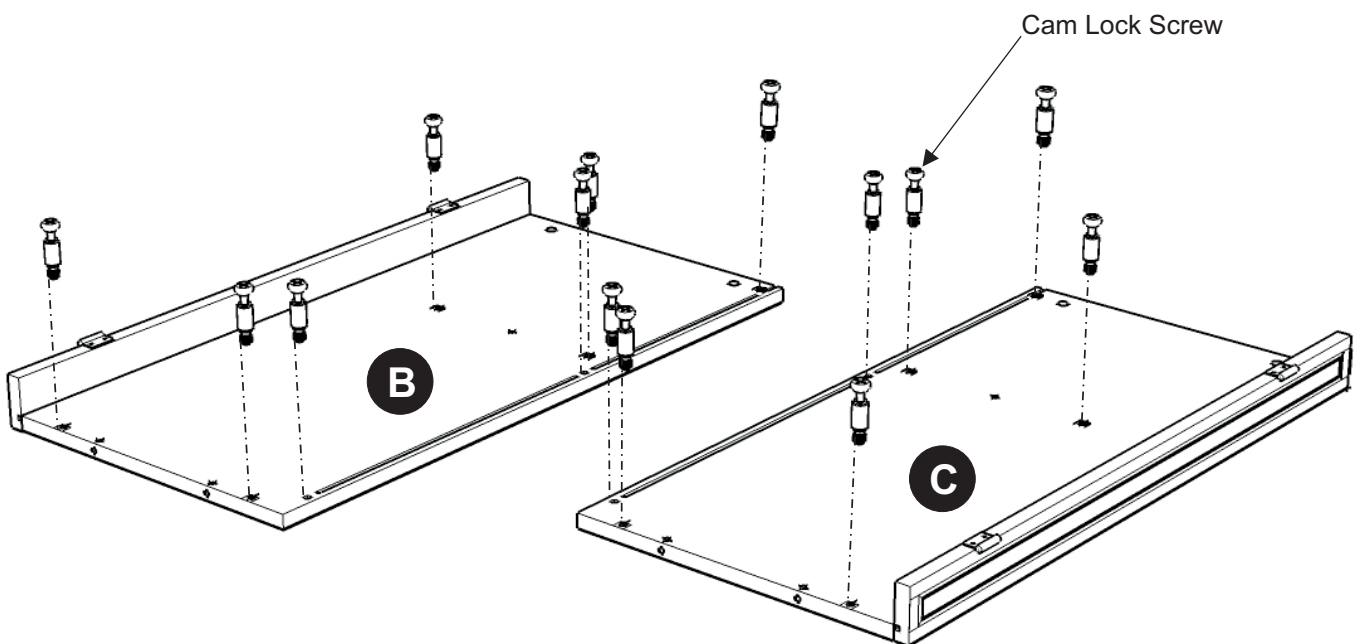

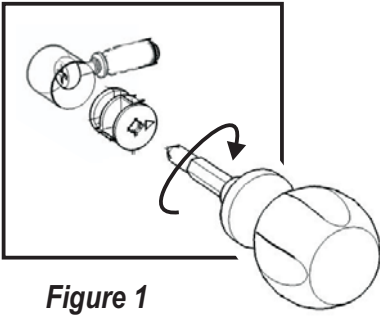
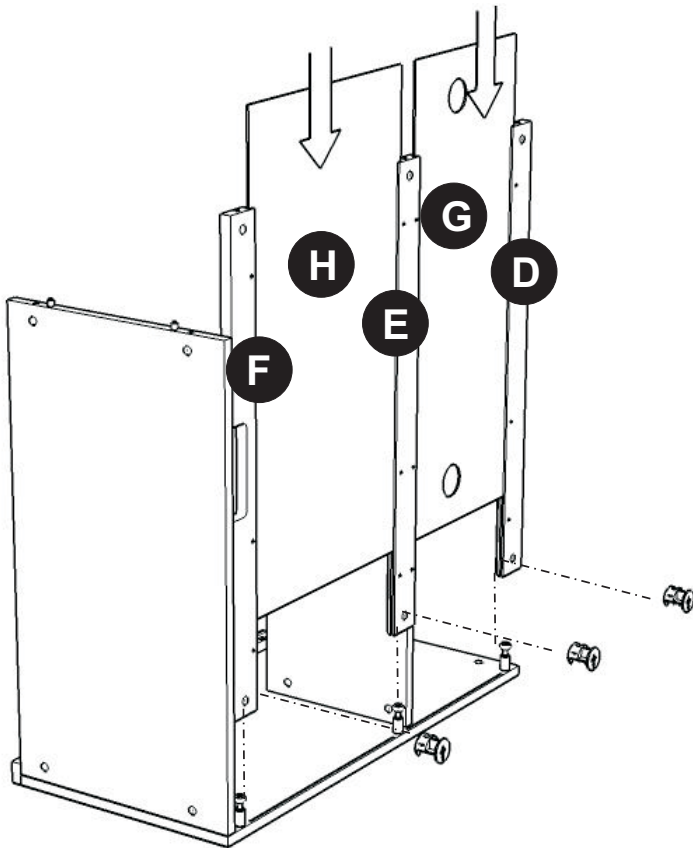
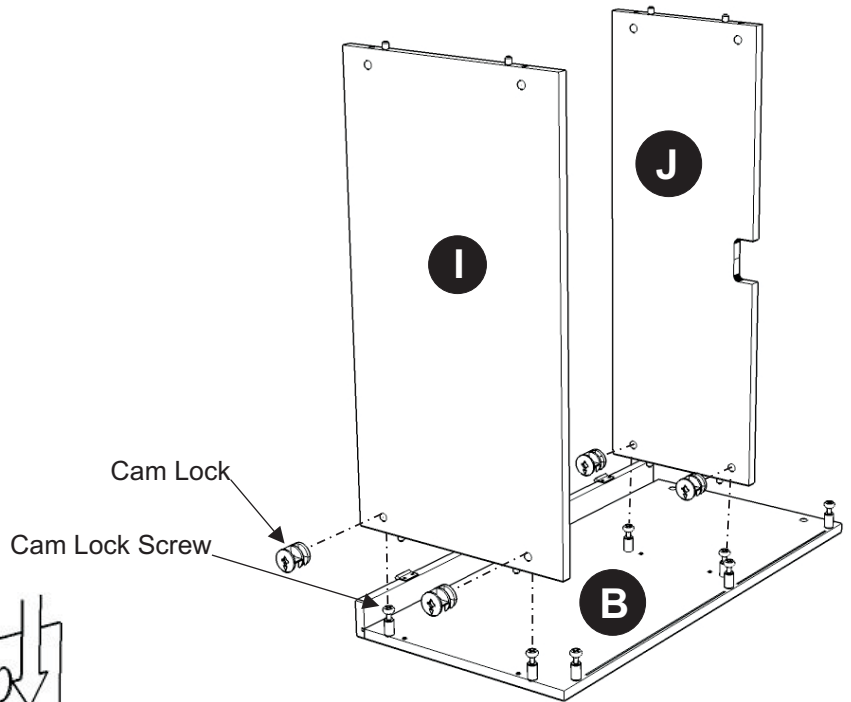

Figure 1

STEP 2

Attach Shelf (J) and Base (I) onto Side Panel (B) using Cam Locks. (see Figure 1)



STEP 3

Attach Stretcher (D), (E) and (F) to the unit using Cam Locks.

Slide Back Panels (H) and (G) into the unit.

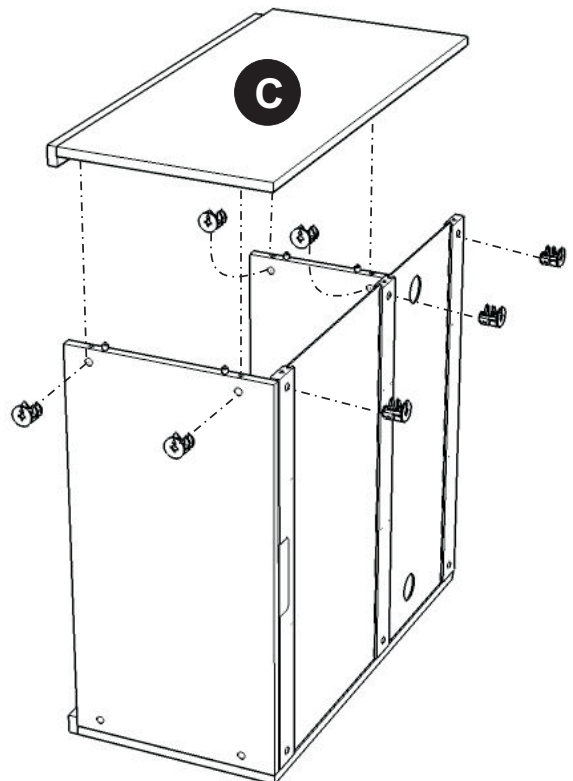

STEP 4

Attach Side Panel (C) to the unit using Cam Locks.

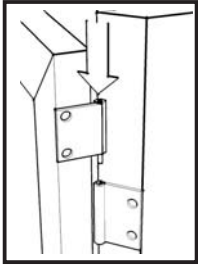

Figure 2

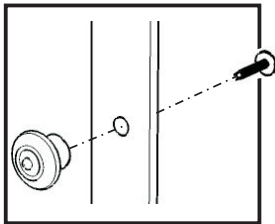
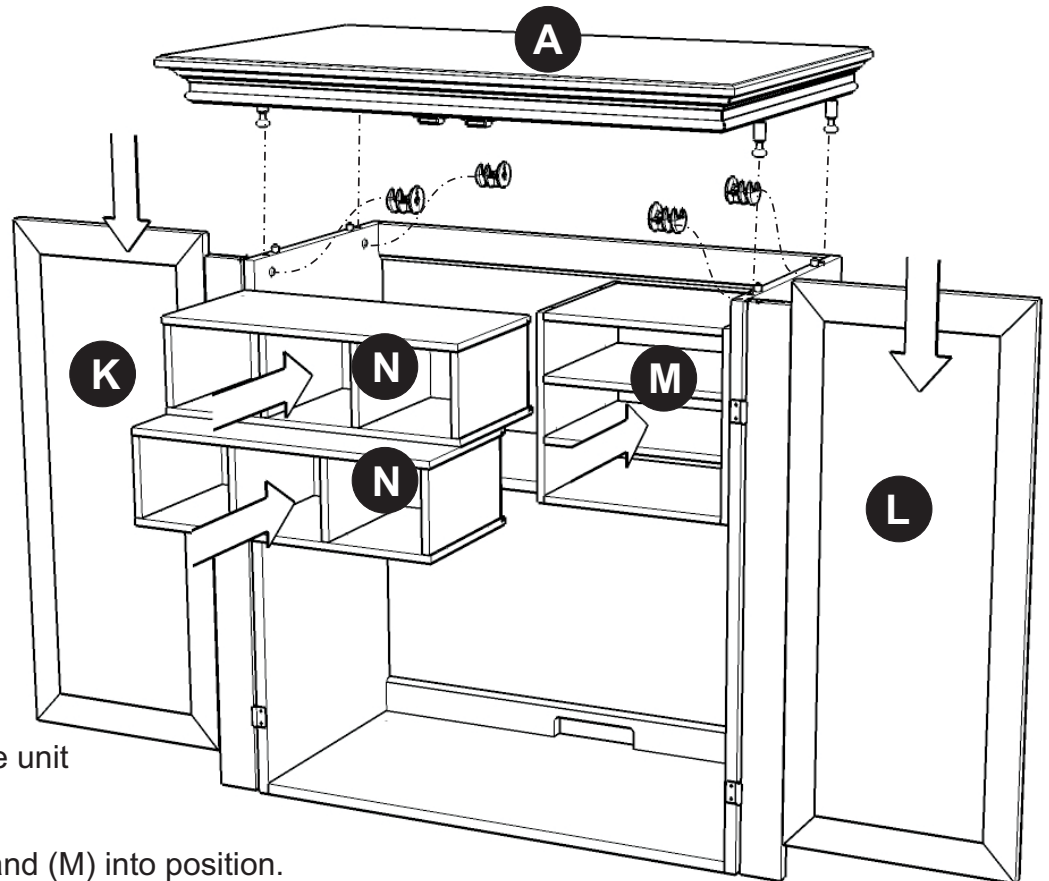

Figure 3



STEP 5

Place Top (A) onto the unit using Cam Locks.

Slide Media Box (N) and (M) into position.

Attach Doors (K) and (L) by sliding the door lift hinges into the side panels lift hinges. (See figure 2)

Assemble Pull Handles to Doors (K) and (L) with Machine Screws. (See figure 3)

STEP 6

Place the assembled Hutch onto Base unit, by using Steel Plate Connector and Wood Screws as shown.

Insert 12X Wood Screws from the back of the unit, tighten up all the Wood Screws.

Note: Please make sure unit is level before tightening these screws.

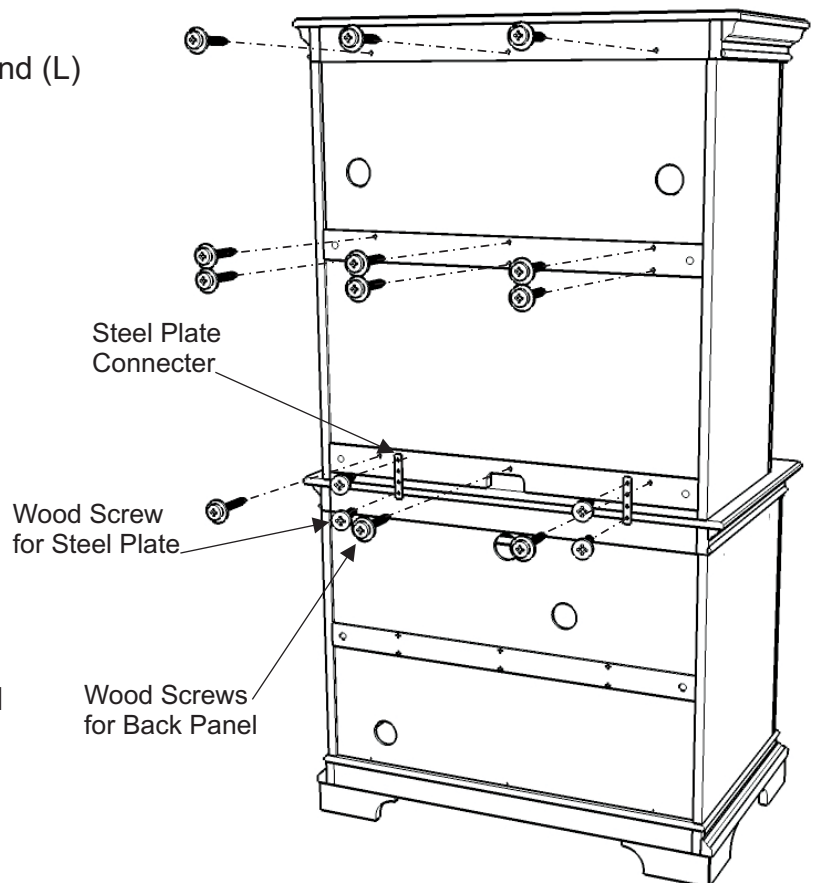

Media Box (M)

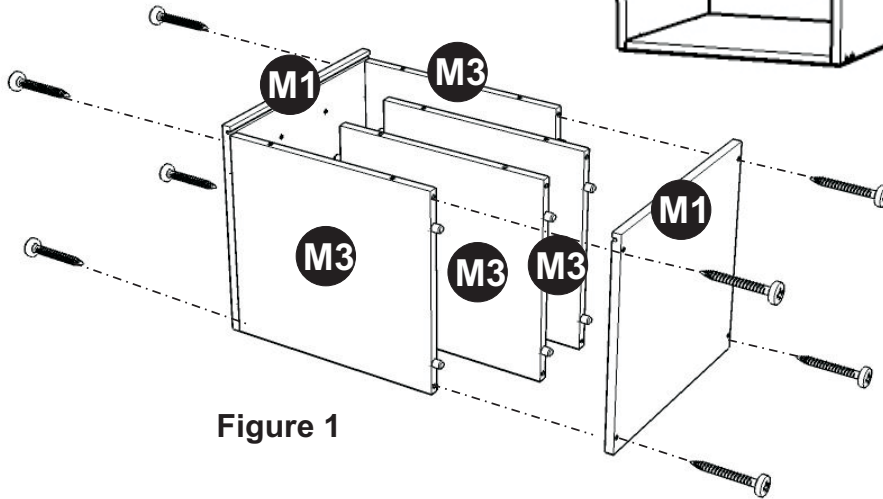

Figure 1

STEP 1

Attach M3 to M1, using a Phillips screw driver and long wood screws (4X), tighten halfway then attach M1 to unit, using long wood screws (4X), tighten halfway. (see Figure 1)

STEP 2

Slide M2 into the grooves in M1. (see Figure 2)

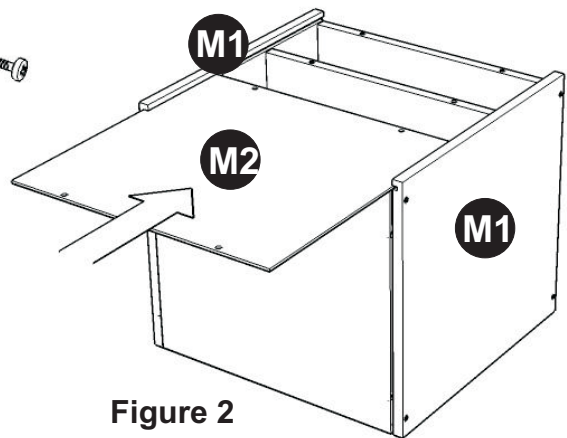

Figure 2

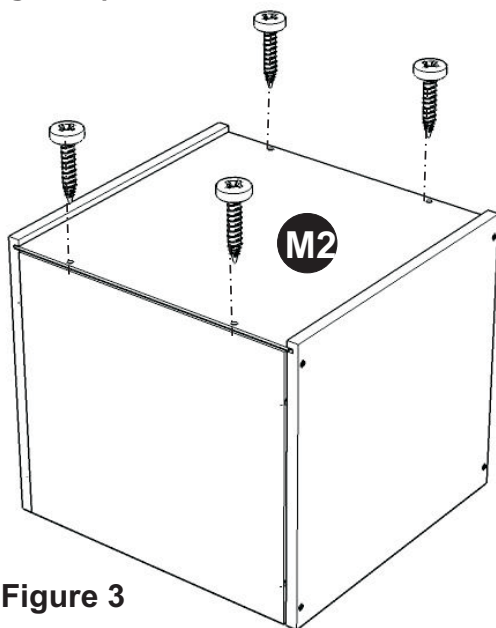

Figure 3

STEP 3

Insert short wood screws (4X) into the pre-drilled holes in M2, tighten screws. (see Figure 3)

Tighten all screws used in Media Box assembly.

Part List



M1.
Media Box
2 pcs.

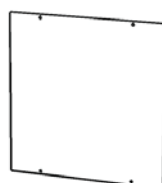

M2.
Media Box
1 pc.



M3.
Media Box
4 pcs.

Media Box (N)

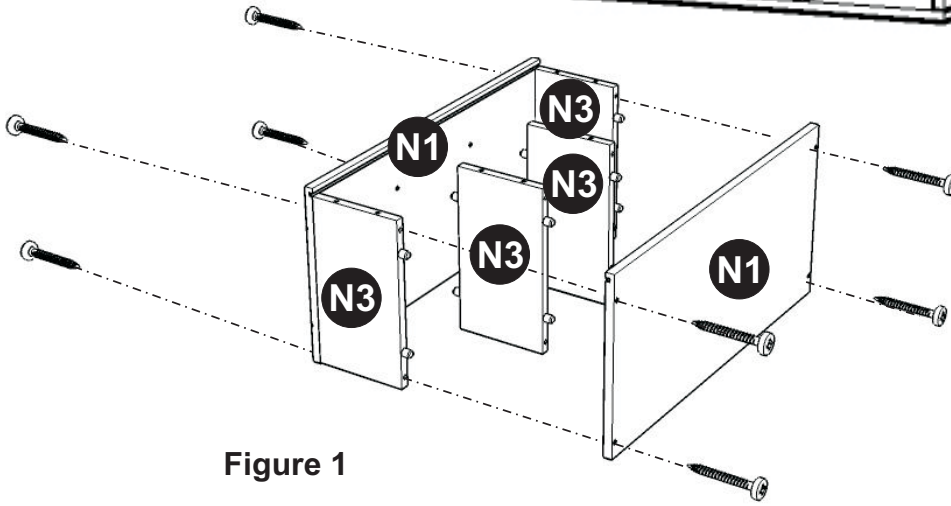
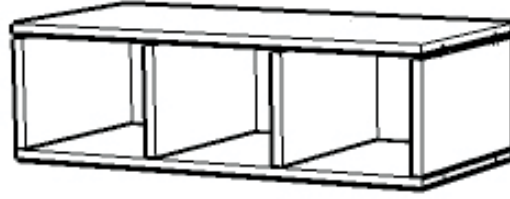

Figure 1

STEP 1

Attach N3 to N1, using a Phillips screw driver and long wood screws (4X), tighten halfway then attach N1 to unit, using long wood screws (4X), tighten halfway. (see Figure 1)

STEP 2

Slide N2 into the grooves in N1. (see Figure 2)

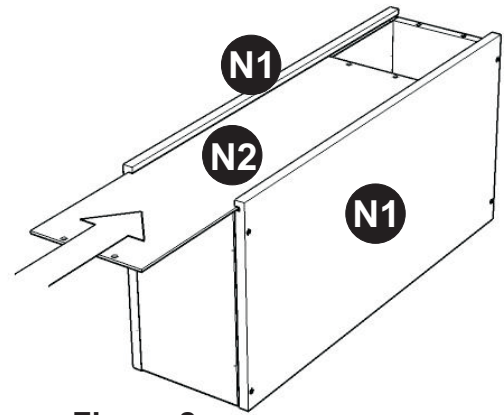

Figure 2

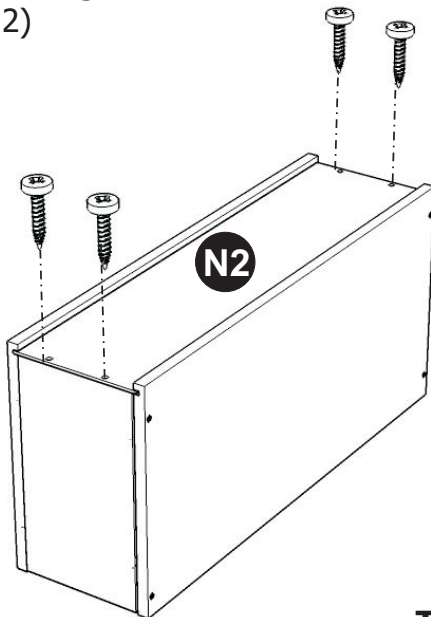

Figure 3

STEP 3

Insert short wood screws (4X) into the pre-drilled holes in N2, tighten screws. (see Figure 3)

Tighten all screws used in Media Box assembly.

Part List



N1.
Media Box
4 pcs.

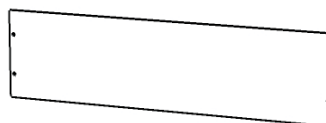

N2.
Media Box
2 pcs.

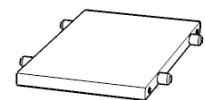

N3.
Media Box
8 pcs.